

# #6280 HYDRAULIC PANTHER<sup>®</sup>

## INSTRUCTION MANUAL

 **Read Manual Before Operating Machine**



***National***  
*Carpet Equipment, Inc.*



9250 XYLON AVENUE NORTH • MINNEAPOLIS, MN 55445 • U.S.A.  
800-245-0267 • 763-535-8206 • FAX 763-535-8255 • FAX 800-648-7124  
WEB SITE: [www.nationalequipment.com](http://www.nationalequipment.com) • E-MAIL: [info@nationalequipment.com](mailto:info@nationalequipment.com)

# 6280 TABLE OF CONTENTS

■ Table of Contents .....	2-3
■ Hydraulic .....	4-5
A. Maintaining A Safe Work Environment .....	4
B. Pressure.....	4-5
C. Flammability .....	5
D. Hydraulic Fluid.....	5
■ Rules for Safe Operation.....	6-9
A. Grounding .....	8
B. Extension Cords .....	9
■ Transportation .....	10-11
A. Transport Wheels .....	10
B. Wheels Engaged/Disengaged .....	10.1
C. Loading .....	11
D. Unloading .....	11.1
■ General Operation.....	12-13
A. Specifications .....	12
B. Machine Start-up Procedure .....	12
C. Maintenance .....	13
D. Inspection Procedure Hydraulic Preventive Maintenance Checklist .....	13
■ Blades .....	14-19
A. Blade Setting .....	14-15
B. Blade Changing.....	15
C. Blade Sharpening .....	16
D. Blade Chart.....	17-17.1
E. Types of Tearouts.....	18-19
■ Procedures .....	20-23
A. Counter Weights .....	20
B. Wheel Adjustment/Removal .....	20
C. Hydraulic Fluid Level and Changing .....	21
D. Tank Removal .....	21
E. Inspection of Internal Parts .....	22
F. Speed Control .....	22
G. Pressure Valve Replacement .....	22
H. Forward and Reverse Switch Replacement.....	22-23
I. Cartridge Replacement .....	23
J. On/Off Switch Wire Diagram .....	23
■ Troubleshooting .....	24
■ Complete Parts List .....	25-28.1

# 6280 TABLE OF CONTENTS

■ Part Numbers and Diagrams.....	29-36
A. External Parts .....	29
B. Rearview External Parts .....	30
C. Base Plate Parts .....	31
D. Idler Assembly Parts .....	32
E. Pump Drive Assembly Parts .....	32
F. Eccentric Assembly Parts .....	32
G. Bearing & Bottom Cover Parts .....	32.1
H. Axle Assembly Parts .....	33
I. Wheel Cleaner Parts .....	33
J. Internal Handle Parts.....	34
K. Handle Parts .....	34
L. Hose Parts.....	34
M. Motor Parts .....	35
N. Body Parts.....	35
O. Switch Parts .....	35.1
P. Cutting Head Parts.....	35.1
Q. Internal Parts Parts .....	36
■ Labels.....	37-37.1
■ Accessories .....	38
■ 120 Volt Wiring Diagram.....	39
■ Hydraulic Line Layout Diagram .....	40
■ Material Safety Data .....	41-46
■ Guarantee.....	47
■ Return Sheet .....	48
■ Blade Order Form.....	

# 6280 HYDRAULIC SAFE OPERATION

## MAINTAINING A SAFE WORK ENVIRONMENT

Establishing a safe working environment in and around your hydraulic equipment is just common sense. The easiest and most effective way to avoid problems is to make sure associates understand their equipment, know how to operate it safely and recognize the danger it represents if handled carelessly. A few things you must be aware of include:

1. **PRESSURE:** Hydraulic fluid under pressure is dangerous and can cause serious injury.
2. **FLAMMABILITY:** When ignited, some hydraulic fluids can explode and/or cause fires.
3. **MECHANICAL:** Hydraulic fluid creates movement, which causes parts of your equipment to move or rotate. Always be aware of what you are doing.
4. **MOISTURE:** Never operate in wet or high moisture conditions without a proper GFI grounded switch. Make sure all electrical fittings, switches, cords plus stain reliefs are in good condition. Always unplug when not in use and when doing any service work.
5. **ELECTRICAL:** Disconnect power before servicing. Unplug cord so it can't be started. Faulty wiring can also be an electrical hazard. A regular preventive maintenance program should always include a wiring check.
6. **TEMPERATURE:** Because this machine operates at a relatively low pressure, overheating is not common. If surface of tank becomes too hot to touch by hand (above 130°), shut off machine and allow to cool off.

## PRESSURE

Our system runs at or below 1,200 psi. Never look for a leak when unit is under pressure. Using your hand could cause serious injury. A few common ways to encounter hydraulic fluid under pressure include:

1. **PINHOLE:** Fluid under pressure can cause serious injury. It can be almost invisible escaping from a pinhole, and it can pierce the skin into the body. Do not touch a pressurized hydraulic hose assembly with any part of your body. If fluid punctures the skin, even if no pain is felt, a serious emergency exists. Obtain medical assistance immediately. Failure to do so can result in loss of the injured part or death.
2. **LEAK:** Keep fittings and hoses tight. Only check and service when not under pressure. Leaking hydraulic fluid is not only unsightly, it's hazardous. In addition to making workplace floors slippery and dangerous, leaks also contaminate the environment. Before cleaning an oil spill, always check EPA, state and local regulations.

## LEAK AT THREAD END/SEAT

**Problem:** Coupling leaks at thread or seat. This may be caused by any of the following:

- a. Missing or damaged O-rings.
- b. Damaged threads or seat angle.
- c. Thread alignment.
- d. Incompatible thread ends or seat angles.
- e. Over or undertorquing.

**Solution:** Remove the connection and inspect.

1. Certain couplings require the use of an O-ring. If it is missing, replace it. If an O-ring is used, check for damage caused by installation or possible material breakdown from heat or fluid incompatibility. Alternative O-ring materials may be required. Replace if necessary.

# 6280 HYDRAULIC SAFE OPERATION

## PRESSURE (continued)

2. Check the threads and/or seat angle for damage that may have occurred prior to or during installation. Any ding or burr may be a potential leak path. Replace if necessary.
3. If the coupling was misaligned during installation, threads may have been damaged. Replace and carefully install.
4. Overtorquing of a threaded connection can stretch and damage threads and mating seat angles. Overtorquing can also damage the staking area of the nut. Undertorquing does not allow proper sealing.

**⚠ CAUTION:** Never check for leaks over hose or hydraulic connections. Instead, use a piece of cardboard to locate a pressurized leak. For drips (low pressure leaks), use a rag to clean the area and determine where the leak originates.

**⚠ CAUTION:** Never touch a pressurized hose assembly. Shut down the hydraulic system before checking hose temperature.

3. **BURST:** Whether due to improper selection or damage, a ruptured hose can cause injury. If it bursts, a worker can be burned, cut, injected or may slip and fall.
4. **COUPLING BLOW-OFF:** If the assembly is not properly made or installed, the coupling could come off and hit or spray a worker, possibly resulting in serious injury. Never operate machine without guards.

## FLAMMABILITY

With the exception of those comprised primarily of water, all hydraulic fluid is flammable when exposed to the proper conditions (including many “fire-resistant” hydraulic fluids).

Leaking pressurized hydraulic fluids may develop a mist or fine spray that can flash or explode upon contact with a cause of ignition. These explosions can be very severe and could result in serious injury or death.

Precautions should be taken to eliminate all ignition sources from contact with escaping fluids, sprays or mists resulting from hydraulic failures. Sources of ignition could be electrical discharges (sparks), open flames, extremely high temperatures, sparks caused by metal-to-metal contact, etc.

## HYDRAULIC FLUID

Only use Texaco Rando 46 Hydraulic Oil or Compatible Fluid Light IS032. Non-compatible fluids could cause damage to unit or serious injury.

**⚠ WARNING:** When using electric tools, always follow basic safety precautions to reduce the risk of electric shock and personal injury.

# 6280 RULES FOR SAFE OPERATION



**READ AND SAVE ALL INSTRUCTIONS FOR FUTURE USE.** Before use, be sure everyone operating this equipment reads and understands this manual as well as any labels packaged with or attached to the machine and components and view the instruction video. Extra copies of the manual and video are available upon request.

- 1. KNOW YOUR EQUIPMENT:** Read this manual and view instruction video carefully to learn equipment applications and limitations as well as potential hazards associated with this type of equipment.
- 2. GROUND YOUR TOOL:** See Grounding.
- 3. AVOID DANGEROUS ENVIRONMENTS:** Do not use in rain, damp or wet locations, or in the presence of explosive atmospheres (gaseous fumes, dust or flammable materials). Remove materials or debris that may be ignited by sparks.
- 4. KEEP WORK AREA CLEAN AND WELL LIT:** Cluttered, dark work areas invite accidents.
- 5. DRESS PROPERLY:** Do not wear loose clothing. These may be caught in moving parts. When working outdoors, wear rubber gloves and insulated non-skid footwear. Keep hands and gloves away from moving parts.
- 6. USE SAFETY EQUIPMENT:** Everyone in the work area should wear safety goggles or glasses complying with current safety standards. Wear hearing protection during extended use and a dust mask for dusty operations. Hard hats, face shields, safety shoes, etc. should be worn when specified or necessary.
- 7. KEEP BYSTANDERS AWAY:** Children and bystanders should be kept at a safe distance from the work area to avoid distracting the operator and contacting the tool or extension cord. Operator should be aware of who is around them and their proximity.
- 8. PROTECT OTHERS IN THE WORK AREA:** Provide barriers or shields as needed to protect others from debris and machine operation.
- 9. USE PROPER ACCESSORIES:** Using accessories that are not recommended may be hazardous. Be sure accessories are properly installed and maintained. Do not delete a guard or other safety device when installing an accessory or attachment.
- 10. CHECK FOR DAMAGED PARTS:** Inspect guards and other parts before use. Check for misalignment, binding of moving parts, improper mounting, broken parts and any other conditions that may affect operation. If abnormal noise or vibration occurs, turn the tool off immediately and have the problem corrected before further use. Do not use damaged equipment. Tag damaged tools "DO NOT USE" until repaired. A guard or other damaged parts should be properly repaired or replaced. For all repairs, insist on only identical National replacement parts.
- 11. REMOVE ALL ADJUSTING KEYS AND WRENCHES:** Make a habit of checking that the adjusting keys, wrenches, etc. are removed from the tool before turning it on.
- 12. GUARD AGAINST ELECTRIC SHOCK:** Prevent body contact with grounded surfaces such as pipes, radiators, ranges and refrigerators. When scoring or making cuts, always check the work area for hidden wires or pipes. Use a Ground Fault Circuit Interrupter (GFCI) to reduce shock hazards.
- 13. AVOID ACCIDENTAL STARTING:** Be sure equipment is turned off before plugging it in. Do not use if the power switch does not turn the machine on and off.
- 14. DO NOT FORCE EQUIPMENT:** Equipment will perform best at the rate for which it was designed. Excessive force only causes operator fatigue, increased wear and reduced control.

# 6280 RULES FOR SAFE OPERATION

**15. KEEP HANDS AWAY FROM ALL CUTTING EDGES AND MOVING PARTS.**

**16. WEAR GLOVES WHEN CHANGING BLADES.**

**17. DO NOT ABUSE CORD:** Never unplug by yanking the cord from the outlet. Pull plug rather than cord to reduce the risk of damage. Keep the cord away from heat, oil, sharp objects, cutting edges and moving parts.

**18. DO NOT OVERREACH. MAINTAIN CONTROL:** Keep proper footing and balance at all times. Maintain a firm grip.

**19. STAY ALERT:** Watch what you are doing, and use common sense. Do not use when you are tired, distracted or under the influence of drugs, alcohol or any medication causing decreased control.

**20. STARTING MACHINE:** On/off switch must be in off position before connecting to power source.

**21. UNPLUG EQUIPMENT:** When it is not in use, unplug tool before changing blades, accessories or performing recommended maintenance or when not in use.

**22. MAINTAIN EQUIPMENT CAREFULLY:** Keep handles dry, clean and free from oil and grease. Keep cutting edges sharp and clean. Follow instructions for lubricating and changing accessories. Periodically inspect tool cords and extension cords for damage. Have damaged parts repaired or replaced.

**23. STORE IDLE EQUIPMENT:** When not in use, store in a dry, secured place. Keep away from children.

**24. MAINTAIN LABELS AND NAMEPLATES:** These carry important information. If unreadable or missing, contact National for a free replacement.

**⚠ WARNING:** Exposure to dust may cause respiratory ailments. Use approved NIOSH or OSHA respirators, safety glasses or face shields, gloves and protective clothing. Provide adequate ventilation to eliminate dust, or to maintain dust level below the Threshold Limit Value for nuisance dust as classified by OSHA.

**25. MACHINE IS HEAVY, DO NOT DROP:** Counter weights are heavy. Take caution when removing or reassembling. Take caution when moving or transporting.

# 6280 RULES FOR SAFE OPERATION

## GROUNDING

**⚠ WARNING:** Improperly connecting the grounding wire can result in the risk of electric shock. Check with a qualified electrician if you are in doubt as to whether the outlet is properly grounded. Do not modify the plug provided with the tool. Never remove the grounding prong from the plug. Do not use the tool if the cord or plug is damaged. If the plug will not fit the outlet, have a proper outlet installed by a qualified electrician.

**⚠ WARNING:** Electrical cords can be hazardous. Misuse can result in fire or death by electrical shock. Read carefully and follow all directions.

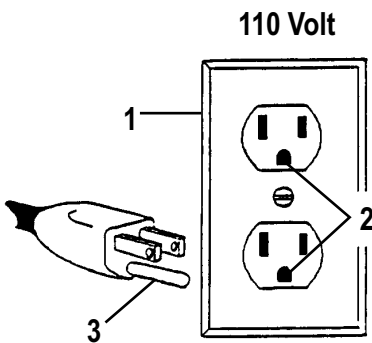

Figure A

1. Cover of grounded outlet box
2. Outlet ground
3. Grounding prong

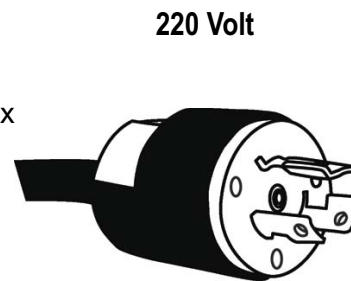

Figure B

### GROUNDING TOOLS: TOOLS WITH THREE PRONG PLUGS

Tools marked "Grounding Required" have a three wire cord and three prong grounding plug. The plug must be connected to a properly grounded outlet (Figure A & B). If the tool should electrically malfunction or break down, grounding provides a low resistance path to carry electricity away from the user, reducing the risk of electric shock.

The grounding prong in the plug is connected through the green wire inside the cord to the grounding system in the tool. The green wire in the cord must be the only wire connected to the tool's grounding system and must never be attached to an electrically "live" terminal.

Your tool must be plugged into an appropriate outlet, properly installed and grounded in accordance with all codes and ordinances. The plug and outlet should look like those in Figure A & B.



# 6280 RULES FOR SAFE OPERATION

## EXTENSION CORDS

**⚠ WARNING:** Electrical cords can be hazardous. Misuse can result in fire or death by electrical shock. Read carefully and follow all directions.

Grounded tools require a three wire extension cord. Double insulated tools can use either a two or three wire extension cord. As the distance from the supply outlet increases, you must use a heavier gauge extension cord. Using extension cords with inadequately sized wire causes a serious drop in voltage, resulting in loss of power and possible tool damage.

The smaller the gauge number of the wire, the greater the capacity of the cord. For example, a 14 gauge cord can carry a higher current than a 16 gauge cord. When using more than one extension cord to make up the total length, be sure each cord contains at least the minimum wire size required. If you are using one extension cord for more than one tool, add the nameplate amperes and use the sum to determine the required minimum wire size.

### GUIDELINES FOR USING EXTENSION CORDS

- If you are using an extension cord outdoors, make sure it is marked with the suffix “W-A” (“W” in Canada) to indicate that it is acceptable for outdoor use.
- Be sure your extension cord is properly wired and in good electrical condition. Always replace a damaged extension cord or have it repaired by a qualified person before using it.
- Protect your extension cords from sharp objects, excessive heat and damp or wet areas.
- Keep away from water. Do not use if wet. 
- Inspect thoroughly before each use. **DO NOT USE IF DAMAGED.**
- Make sure equipment is OFF before connecting cord outlet.
- FULLY INSERT plug into outlet.
- Do not remove, bend or modify any metal prongs or pins of cord.
- Do not use excessive force to make connections.
- Do not connect a three prong plug to a two-hole cord.
- Avoid overheating. Uncoil cord and do not cover it with any material.
- Do not walk on cord.
- Do not drive, drag or place objects over cord.

**READ AND SAVE ALL INSTRUCTIONS FOR FUTURE REFERENCE.**



# 6280 TRANSPORTATION

## TRANSPORT WHEEL ASSEMBLY

- Transport wheels help to eliminate damage to flooring and make movement of unit easier.

## ATTACHING TRANSPORT WHEELS

- Remove two outside blade cover bolts (See Figure A).

**⚠ WARNING:** Make sure machine is stable and secure on blocks.

- Tip machine back and block up front of machine so cutting head has enough clearance for front wheel assembly to fit under. See Figure B or, lay unit on side and block up (See Figure C).
- Mount front wheel assembly over blade cover (See Figure A). Replace two outside blade cover bolts.
- Remove blocks.
- DO NOT leave machine in transport mode while in transit in vehicle without machine being secured.

### #6280-301 Front Transport Wheel

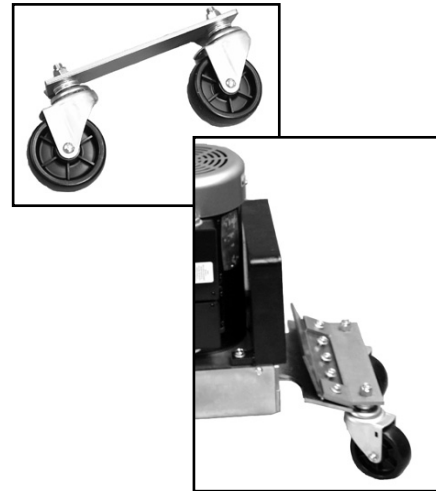

## REMOVAL OF TRANSPORT WHEELS

- Reverse procedure from above.

**⚠ WARNING:** Never have transport wheel assembly mounted onto machine or wheels disengaged when going up or down a loading ramp or incline. (See Page 10.1). Failure to do so could cause machine runaway, damage to machine, damage to property or cause serious injury.

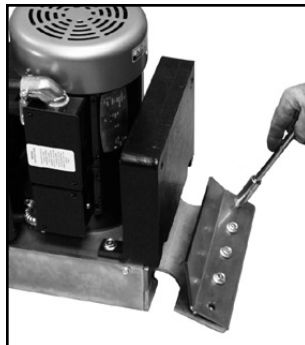

Figure A

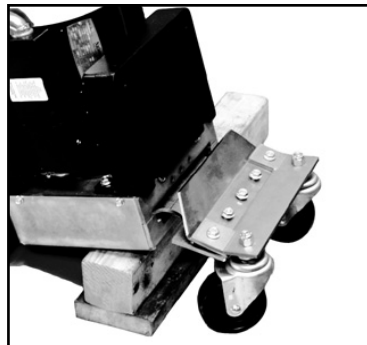

Figure B

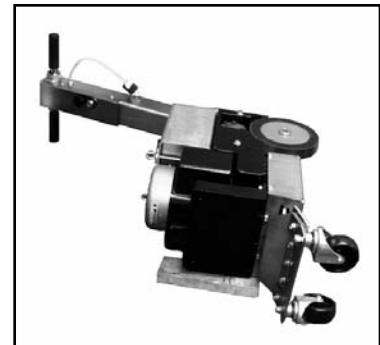

Figure C

# 6280 TRANSPORTATION

Wheels engage and disengage for easier maneuverability. Wheels in the “engage mode” are secured with the axle pins (See Figure A). This engages the wheels for the machine to be self-propelled.

When wheels are in the “disengage mode” (See Figure B). Machine can be moved around freely when the machine IS NOT under power.

## WHEELS ENGAGING OR DISENGAGING

### DISENGAGING WHEELS

**⚠ WARNING:** Never load or unload machine on a ramp or incline when wheels are in the disengage mode. Failure to do so could cause machine runaway, damage to machine, damage to property or cause serious injury.

Move machine so pin is vertical (See Figure C). Pull up on end of pin to release. Slide pin out. Repeat on second wheel. **Note:** Keeping axle pin facing straight up will make re-engaging easier.

### RE-ENGAGING WHEELS

Line up wheel hub hole and axle hole (See Figure D). Insert axle pin and secure pin end. Repeat on second wheel.

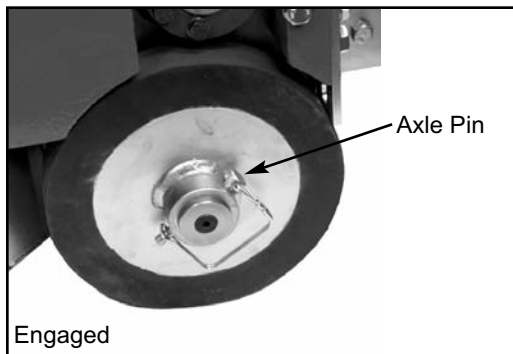

Figure A

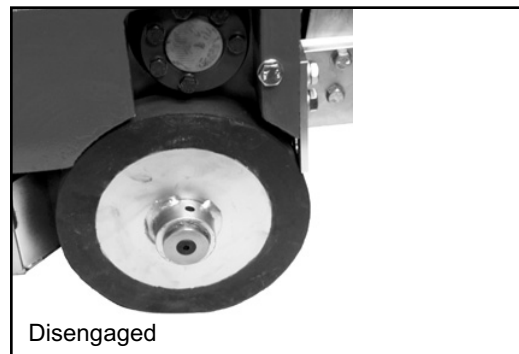

Figure B

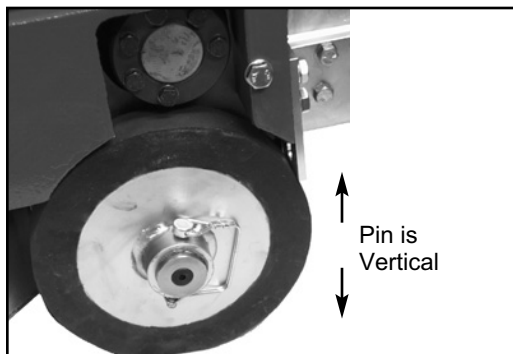

Figure C

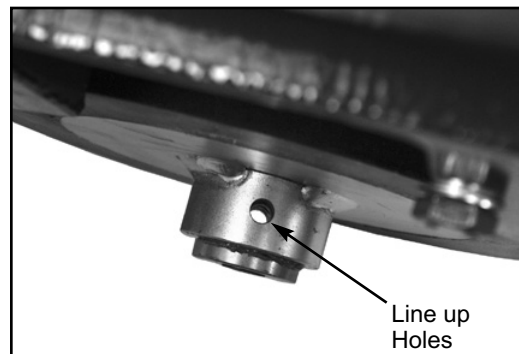

Figure D

**⚠ WARNING:** Never have transport wheel assembly mounted onto machine when wheels are in the disengage mode.

# 6280 TRANSPORTATION

**⚠ WARNING:** When maneuvering machine on any type of a incline (ramp, hill, etc.), wheel engage pins MUST be in place (in engaged mode) (See Figure B) and counterweights removed.

## LOADING

ALWAYS REMOVE ALL COUNTERWEIGHTS AND BLADES BEFORE LOADING OR UNLOADING.

## LIFTING BAIL

- Easy loading when not driving or using a ramp.
- Use rope, hook system or chain through eyelets located on top of machine (See Figure A).
- Location on lifting bails centrally locates balance of the machine to safely pick-up machine.
- Raise machine with a fork lift or winch.

**⚠ WARNING:** Keep hands and feet out from under machine.

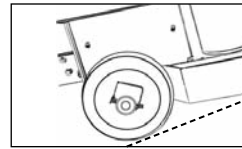

**CORRECT**

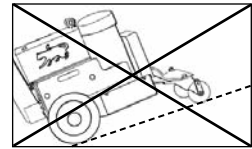

**INCORRECT**

## RAMP

**⚠ WARNING:** Only load or unload machine on a ramp with wheel pins engaged (engage mode) (See Figure B) and counterweights removed. Failure to do so could cause machine runaway, damage to machine, damage to property or cause serious injury. See Page 10.1 for wheel engage mode.

**⚠ WARNING:** Make sure ramp is secure before using. Failure to do so could cause ramp to fall away from truck, causing damage to the machine and/or injury to the operator.

- All counterweights, blades and transport wheels must be removed before unloading (or loading).
- Make sure ramp is clean and dry, free of grease or oil.
- Attach ramp securely to back of vehicle, making sure there is good contact (See Figure C).
- Position machine at back of ramp (See Figure A). Engage power switch and drive onto vehicle.

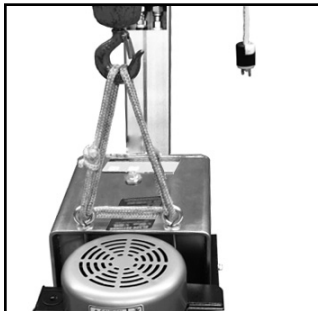

**Figure A**

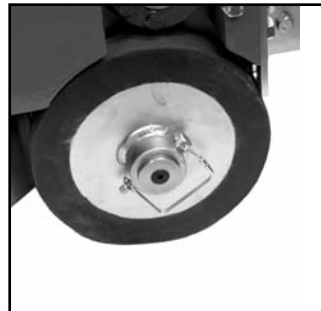

**Figure B**

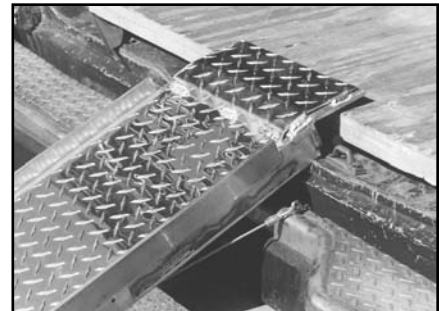

**Figure C**

# 6280 TRANSPORTATION

## UNLOADING

- Position machine at the back of the truck in line with the ramp (See Figure B).
- Carefully move machine onto ramp leaving cutting head down (in contact with ramp surface).

**⚠ WARNING:** Ramp must have good contact with the back of the vehicle. Failure to do so could cause ramp to lose contact with back of vehicle resulting in damage to the machine or injury to the operator.

- Even without counterweights machine weighs 250 pounds
- Make sure you have machine under control. Failure to do so could cause machine runaway, damage to machine, damage to property or cause serious injury.
- Slowly back machine down ramp.

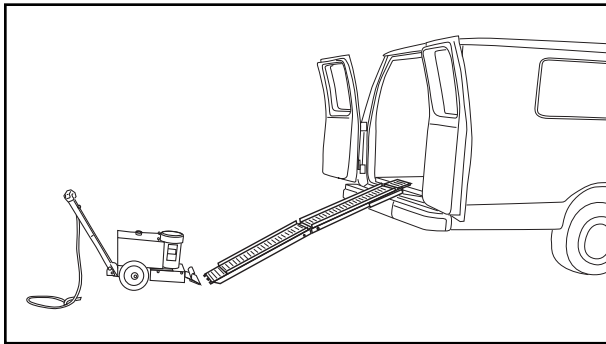

Figure A

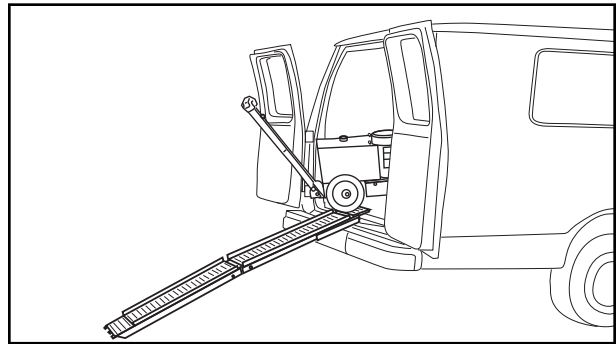
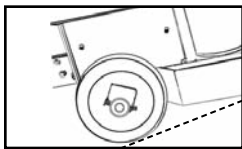
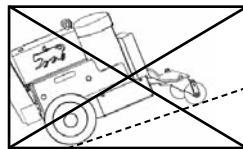

Figure B



CORRECT



INCORRECT

**⚠ WARNING:** Never load or unload machine on a ramp or incline when wheels are in the disengage mode. Failure to do so could cause machine runaway, damage to machine, damage to property or cause serious injury.

# 6280 GENERAL OPERATION

## SPECIFICATIONS

SPECIFICATIONS		#6280
Length:		27.5"
Width:		13"
Height:		41"
Weight (machine only):		360 lbs.
Speed:		10 - 45 feet per minute
MOTOR INFORMATION		
RPM:		3450
Volts:		115
HP:		1½
Amps-Full Load:		13
		Continuous Duty

A well-maintained machine is a productive machine. If not properly maintained, it could be unsafe and could break down. A scheduled maintenance program should insure a long system life and a safe work environment.

## MACHINE START UP PROCEDURE

### TO RUN MACHINE:

1. Machine **MUST** be off before plugging machine into power source.
2. Plug machine into outlet.
3. Turn speed control to slowest position.
4. Turn machine on.
5. Engage forward or reverse switch.
6. Increase speed control to desired speed.

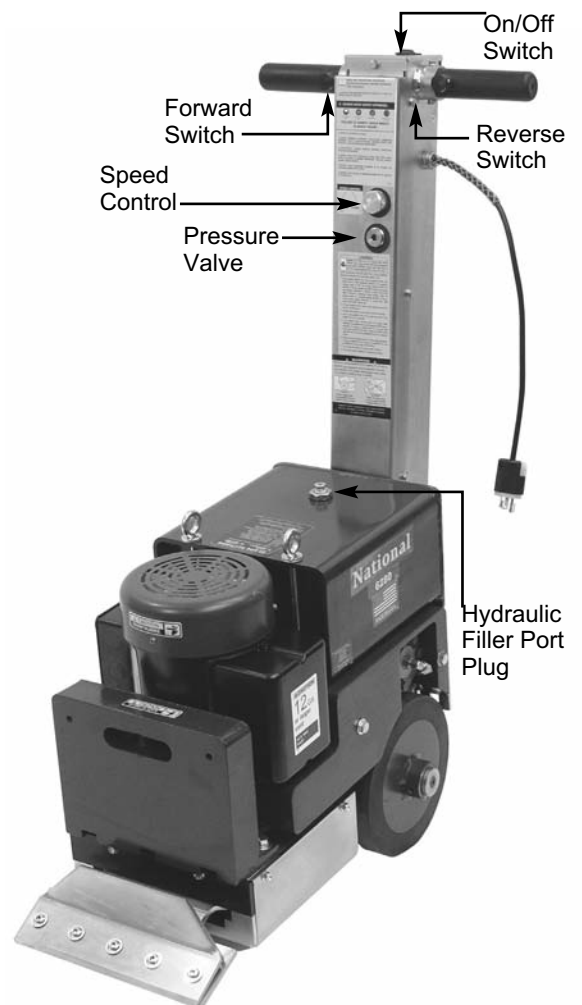

# 6280 GENERAL OPERATION

## MAINTENANCE

1. Always wear eye protection.
2. Keep flammable and fragile objects away from this tool.
3. Always check nuts and bolts to make sure they are tight.
4. Always use the tool with proper voltage specified in the machine's name plate.
5. Always keep guards in place.
6. Do not operate around water or wet conditions without use of GFI on cord.
7. Use properly grounded cord and receptacle.
8. Unplug from power before servicing.
9. Use 12 gauge or heavier wire cord, not exceeding 50 feet in length.
10. Do not force machine.
11. Do not alter machine.
12. Pressure valve has been factory set and should NOT be tampered with.
13. Hydraulic Fluid: Keep clean and at a proper level. See Page 21.
14. Keep wheels free from debris. See page 20.

## INSPECTION PROCEDURE HYDRAULIC PREVENTIVE MAINTENANCE CHECKLIST

By following this preventive maintenance checklist, you can maintain your equipment hose efficiently, safely and with very little effort. Each step is covered in detail in the following section.

 **WARNING:** Do not lock wheel drive into a permanent on position. If operator would lose control or be disabled, machine continues to operate.

- Always turn off and unplug electrical source before servicing.
- Place equipment and components in a safe or neutral position.
- Remove access panels (if any) and inspect hose and fittings for damage or leaks.
- Repair or replace as needed.
- Inspect all hydraulic components.
- Reinstall the access panels.
- Turn power back on.
- Be aware of your equipment, always look and listen for anything unusual.

# 6280 BLADES

## BLADE SETTING

- Dull blades greatly reduce cutting ability. Re-sharpen or replace as needed.
- Proper blade size and placement, depending on material and sub-floor type, affects performance.
- The harder a job comes up, for best results, use a smaller blade.
- Start with a narrow blade, then increase blade size to optimize cutting pass. Narrower blades work easier than wider blades and usually clean the floor better. Wider is not always better or faster.
- Normally bevel on blade is up for concrete. Bevel down for wood or soft sub-floors.



- Wood or wood like floors: pound down or remove any nails or metal obstruction to avoid blade damage.
- Blades can be offset in cutting head for easier access to toe kicks or removal along the wall (See Figure A).
- Sheet vinyl, solid vinyl, rubber tile, urethane or PVC sheet roofing, will need to be scored for best removal results. Nationals #584 Scoring Tool (See Figure B).
- Score flooring to the width of the blade (See Figure C).
- Keep in mind, narrow width blades will make a cleaner floor surface.
- KEEP BLADES SHARP!
- Dull blades greatly affect the performance of the machine.

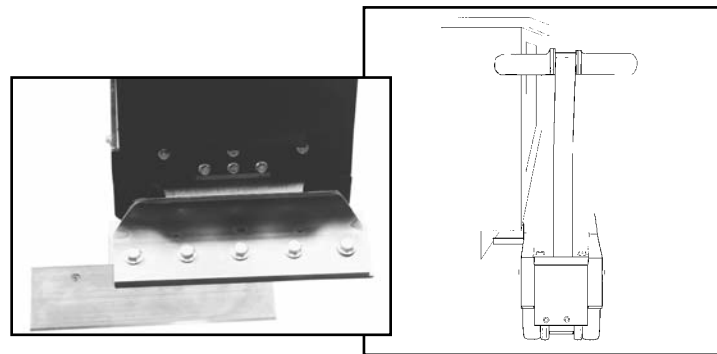

Figure A

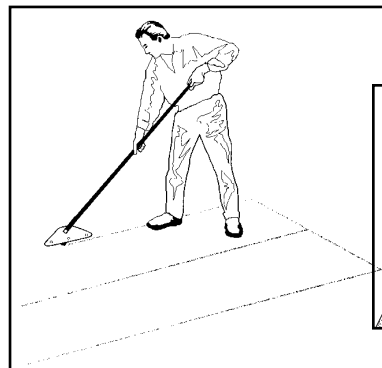

Figure B

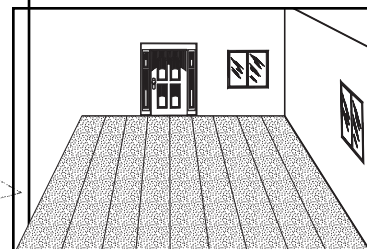

Figure C



# 6280 BLADES

## BLADE SETTING (continued)

- Self scoring blades are available in a number of sizes. These blades eliminate the need for pre-scoring material. Depending upon the type of material being removed and the sharpness of the blade and scoring wings, the self scoring blades may make it harder to control the machine.
- Keep scoring wings sharp at all times.
- Keep your work area clean and clear of debris.
- After you have removed a portion of material, remove it out of the way. This will give the machine maximum performance and help to keep the work area safe.

## BLADE CHANGING

**⚠ CAUTION:** Blades are sharp.

- Sharp blades are imperative for good performance.
- Always wear gloves when changing blades.
- Use supplied extended wrench or a socket wrench with at least a 3" extension to keep hand safely away from the sharp edge of the blade.
  1. Place a block under the front of the machine as shown in Figure A, using a flat piece of 2 x 4 or something similar.
  2. Loosen five (5) hex head bolts with extended bolt wrench (See Figure B). It is not necessary to remove bolts. Place blade into cutting head, sliding all the way back to the bolts. If the blade is wider than the cutting head, center blade to head. If blade is smaller than the cutting head, first pass blade should be mounted in center of the cutting head. After first pass is made, blade can be offset in head to allow wheels to keep even contact with the floor and allow easy access to the wall.

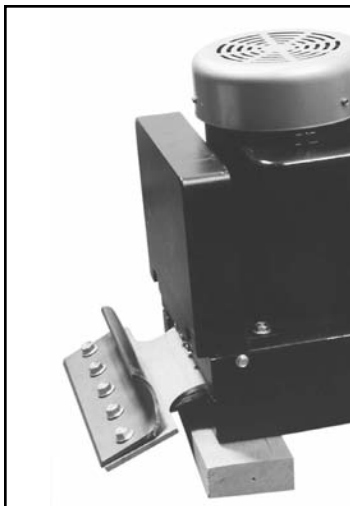

Figure A



Figure B

# 6280 BLADES

## BLADE SHARPENING

- Always wear gloves and safety glasses.
- Using hand grinder, block up front of machine so blade is off the floor.
- Grind blade using a 4" diameter disk with 120 or finer grit. Be careful not to catch disk on edge or corner of blade. Blade bevel up. See Figure A. Blade bevel down (See Figure B).
- Pass grinder back and forth along blade edge being careful to hold grinder at proper angle of blade. Grind until sharp.
- Using a good quality fine tooth hand file, use same procedure as above (See Figure C).
- Blades are sharp. Use extreme caution.
- Have plenty of sharp blades on each job so on-the-job blade sharpening is eliminated.
- It is best to resharpen dull blades on proper bench or belt grinder in the shop, so the blades are ready for the next job.

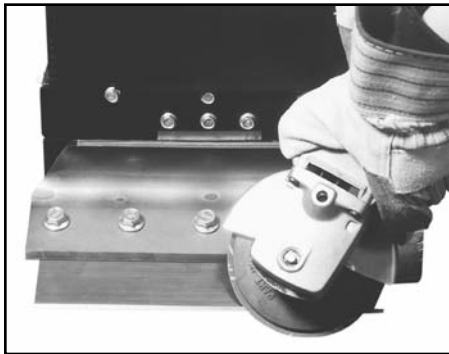

Figure A



Figure B

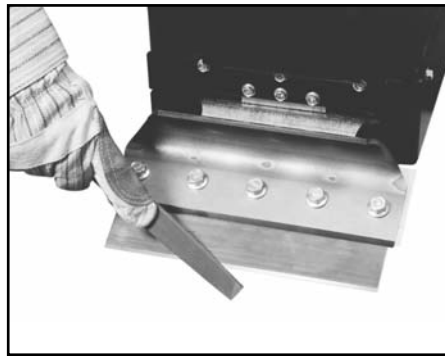
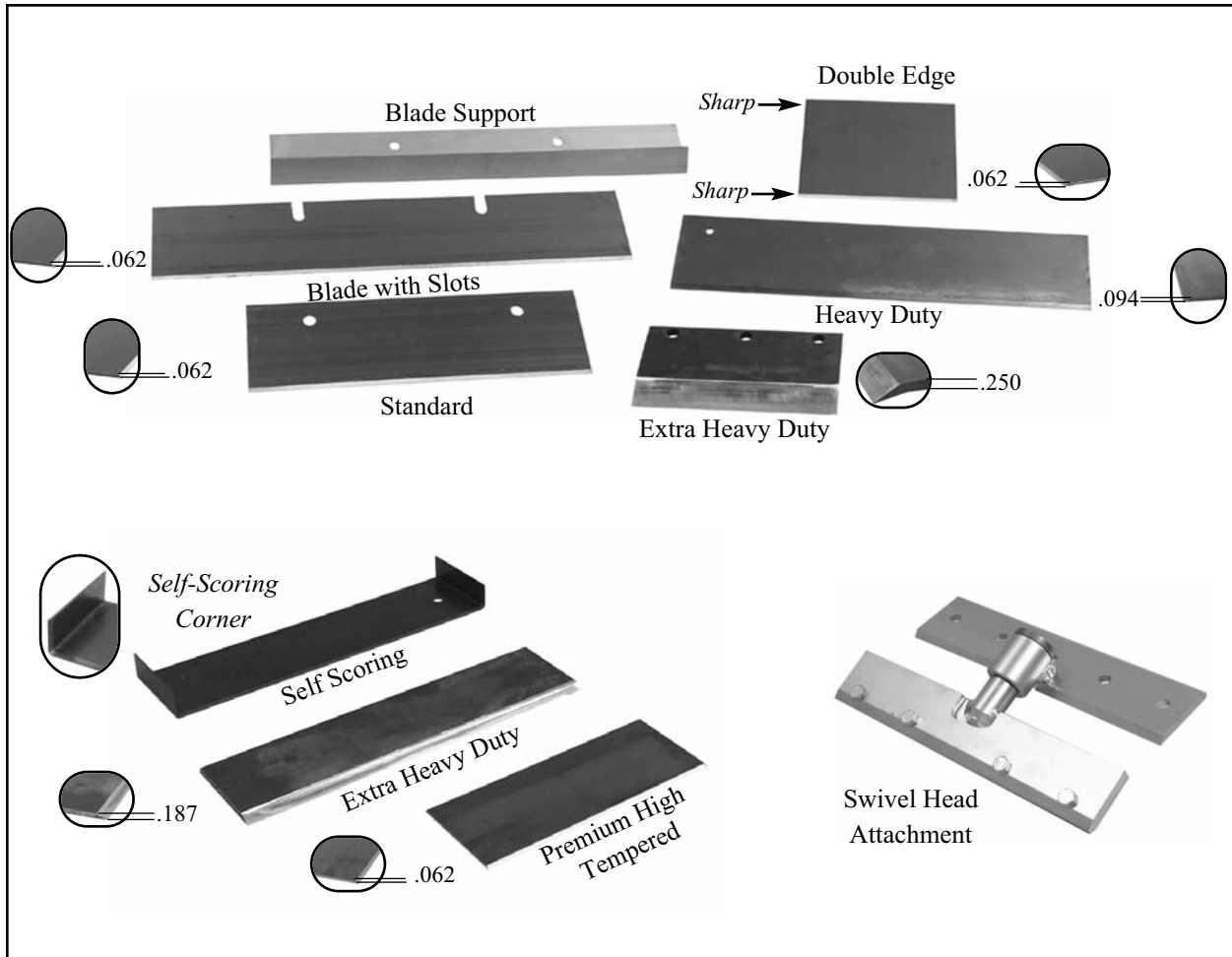
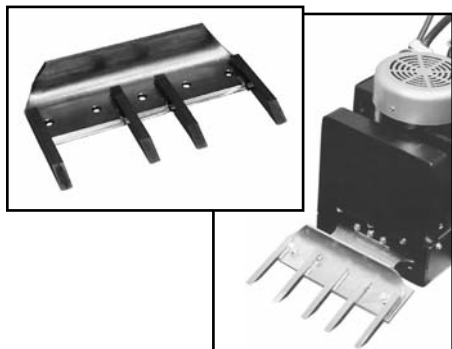

Figure C

# 6280 BLADES



**SELF SCORING BLADES:** Eliminates pre-scoring carpet. See sizes and accessories on Page 17.1.



**#6253 RIPPER TEETH:** Used on real hard to remove goods; Hardwood, Vct and some ceramics

# 6280 BLADES

Part #	Description	Application	Thickness
#130-S	3" x 10" Blade with slots	Glued down carpet, tile or resilient	.062
#130-D	#130 Blade with both edges sharpened	Carpet, tile or resilient on wood & concrete floors	.062
#131-S	3" x 16" Blade with slots	Glued down rubber carpet, floor accumulation	.062
#135	5" x 16" Blade	Rubber back carpet on wood or concrete floors, excellent for cleanup and longer durability	.062
#136	5" x 8" Blade	Removal of wood flooring	.062
#147	4" x 6" Blade	Tile or linoleum on concrete floors	.062
#147-D	#147 Blade with both edges sharpened	Tile or linoleum on concrete floors	.062
#148	5" x 6" Blade	Tile or linoleum on wood floors	.062
#148-D	#148 Blade with both edges sharpened	Tile or linoleum on wood floors	.062
#363-2	3/4" x 8" Scraper Blade (50/pkg)	Razor sharp, super hard for scraping thin epoxies, thin mil coatings like; urethane paint, poured elastomeric coatings up to 60 mil, hard to remove adhesive and much more	.032
#368-8	7/8" x 8" Razor/Scraper Blade (50/pkg)		.045
#368-12	7/8" x 12" Razor/Scraper Blade (50/pkg)		.045
#368-15	7/8" x 15" Razor/Scraper Blade (50/pkg)		.045
#6253	Panther Self-Propelled Ripper Teeth	Difficult surfaces: ceramic, hardwood, heavy tile, etc.	.062
#6255-BU	4" x 6" Self Scoring Blade - Bevel Up	Works on attached cushion, Unitary or secondary backing, vinyl backing, soft to medium Pvc, linoleum, carpet tiles, soft cork, Enhancer and Uniband hot melts	.062
#6257-BU	3" x 9" Self Scoring Blade - Bevel Up		.062
#6258-BU	3" x 12" Self Scoring Blade - Bevel Up		.062
#6259-BU	3" x 14" Self Scoring Blade - Bevel Up		.062
#6277-BU	3" x 12" Self Scoring Blade		Same application as the .062 blade. 45° angle, self scoring wings for easy sharpening. The thickness greatly reduces breakage.
#6278-BU	3" x 14" Self Scoring Blade		.094
#6270	1-1/2" x 3" Extra Heavy Duty Blade	Ultra tough coatings, ceramic & hardwood	.250
#6271	3" x 6" Extra Heavy Duty Blade	Ultra tough coatings, ceramic & hardwood	.250
#6273	3" x 11" Extra Heavy Duty Blade	Ultra tough coatings, ceramic & hardwood	.250
#6280-500	Holds razor blades up to 1" wide	Unique attachment rotates to use the other sharp edge without having to change blade. Works on thin soft coatings, paint, hard to remove gummy or dry adhesives.	
#6281	3" x 8" Heavy Duty Blade	A heavy duty blade that still gives a little flex. Made with Nationals proven blade hardening process, these blades will stay sharper longer with better overall performance than any other blade on the market. Works on Vct, Vat, wood, tile, rubber epoxy, thin-set, elastomeric coatings, scraping thin-set, glued ceramic	.094
#6282	3" x 14" Heavy Duty Blade		.094
#6284	3" x 12" Heavy Duty Blade		.094
#6285	3" x 6" Heavy Duty Blade		.094
#6286	3" x 10" Heavy Duty Blade		.094
#6290	3" x 6" Extra Heavy Duty Blade		Extremely hard, high abrasion alloy for tough tear-up situations. Vct, Vat, wood, tile, thin ceramic, re-scraping thin-set, all carpets, cork, elastomeric coatings, re-scraping rubber and urethane coatings. Holds the edge extremely well.
#6291	3" x 8" Extra Heavy Duty Blade	.187	
#6292	3" x 12" Extra Heavy Duty Blade	.187	
#6293	3" x 14" Extra Heavy Duty Blade	.187	
#7050-200	3" x 6" Premium High Tempered Blade	Ultra high quality spring steel is extra hard for long blade life between sharpening. Works on all glue down carpets, Vct, Vat, rubber tile, cork, re-scraping adhesive, elastomeric coatings. Great for floor accumulations	
#7050-201	3" x 8" Premium High Tempered Blade		.062
#7050-202	3" x 10" Premium High Tempered Blade		.062
#7050-203	3" x 12" Premium High Tempered Blade		.062
#7050-204	3" x 14" Premium High Tempered Blade		.062
#7080	3" x 8" Increased Angle Blade	Mainly used for VCT but can be used on most other applications. Supplies more of an angle when needed. Prevents machine from jumping off material.	.062
#7081	3" x 10" Increased Angle Blade		.062

# 6280 BLADES

**⚠ WARNING:** Never remove flooring containing asbestos without fully understanding proper state and federal procedures and guidelines.

## TYPES OF TEAROUTS

### REMOVAL MATERIALS

- **VCT TILE:** Never use a blade wider than the size of the tile being removed (See Figure A). If goods being removed still do not come up clean or machine jumps on top of goods, reduce blade size to a smaller blade until proper blade size is found or use a smaller portion of the blade.
- **PURE VINYL RUBBER TILE:** Goods will need to be scored down to 10 to 12 inches for proper removal (See Figure B). Self scoring blades can be used with some materials. A 10" blade is recommended for this product, but determine what size blade works best.
- **CERAMIC (Glued with Double Duty or Mudsets):** Before removing ceramic tile, tiles will have to be pre-broke with a mallet or large hammer. On small random block styles of tile, pre-breaking may not be necessary. Open an area large enough for machine or blade to fit in, or start from a doorway. Keep work area clean to keep good wheel contact with floor. Use slow speed and small blades. Ripper Teeth may need to be used first.
- **DIRECT GLUED CARPET:** Can be done with either self scoring blades (Figure D) or pre-score carpet to blade width prior to stripping with #584 Scoring Tool. Pre-scored carpet makes machine easier to control and blades stay sharper longer. Blades up to 16" wide can be used. Normally 12" to 14" blades are used on direct glued carpet, secondary backed, unitary, double glued, vinyl foam, urethane foam. Latex foams come up easily with a 16" blade.
- **HARD TO REMOVE SURFACES:** Ripper teeth can be used on hard to remove goods (See Figure C). Hardwood, VCT, and some ceramics give machine operators super high impact (PSI).

1. Remove five (5) hex head bolts.
2. Remove blade holder.
3. Replace with Ripper Teeth plate. Replace and tighten five (5) hex head screws.

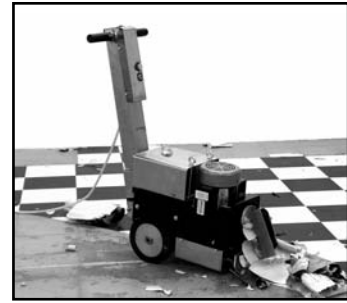

Figure A



Figure B



Figure C

Bevel Up

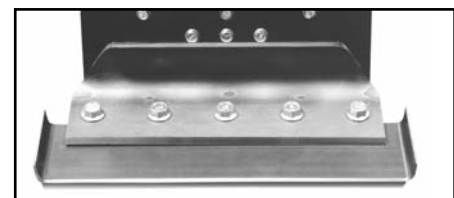

Figure D

# 6280 TYPES OF TEAR-OUT

## TYPES OF TEAROUTS (continued)

### SUBFLOOR SURFACES

- **WOOD:** When working over plywood sub-flooring, try to run machine in the same direction as the grain in the wood. Blade in most cases bevel down. On solid wood floors like plank, run in the same direction as the plank, not cross grain or cross plank. Removing the front counterweight will help on all soft surfaces.
- **CONCRETE:** When working on concrete slab, normal blade position is bevel up for best performance, especially when cleaning adhesive. On occasion, bevel down gives better blade life. Test each job for best performance.
- **GIBCRETE AND SOFT POURED FLOORING:** Usually require blade bevel down to create a better wearing surface, although bevel up may work if front counterweight is removed.



**BEVEL DOWN**



**BEVEL UP**

**⚠ CAUTION:** Beware of expansion joints and floor mounted receptacles or other obstacles in the floor.

### EYE PROTECTION SHOULD BE USED AT ALL TIMES.

- **GLUED HARD WOOD FLOORING:** A 10" blade is recommended for regular adhesive, a 6" blade for epoxy. For proper removal of hardwood flooring (plank solid, plank laminated, parkay laminated), flooring must be scored to blade width. This is done by using a circular saw set at a depth of 99% of the thickness of the board, just missing the subfloor surface when on concrete (See Figure A). A chalk line for scoring lines can be used across the floor the width of the blade (See Figure B). A ripping guide attached to the saw can be used to eliminate chalk line marks. Open an area large enough to fit machine or start from a doorway. It is important to keep all debris cleaned up for maximum performance of machine. True Parkay flooring scoring is not necessary. It will come up in small pieces.

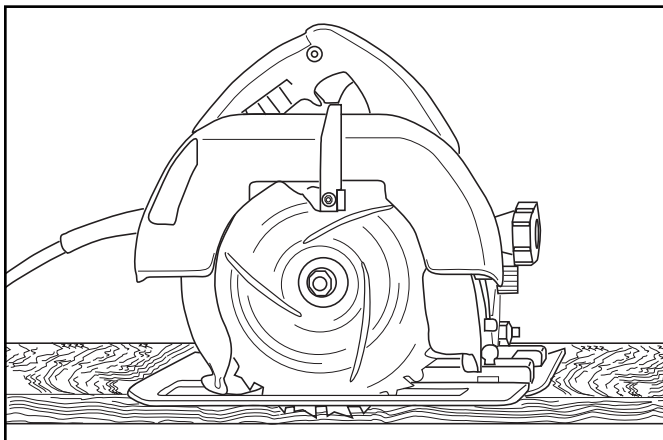

**Figure A**

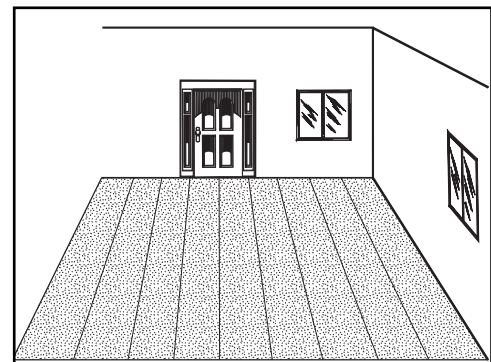

**Figure B**

# 6280 PROCEDURES

## COUNTER WEIGHTS

- It is not necessary to have counterweights on to use machine. Use only as needed (See Figure A).
- Use 9/16" blade wrench (supplied). Each counterweight is attached with two 3/8" bolts. Remove bolts and counterweights. Weights are heavy, use caution when removing or mounting.
- Weights – 44 lbs., front weight – 41 lbs., each side weight.
- Machine total weight with counterweights – 378 lbs..
- Machine weight without counterweights – 250 lbs..
- Optional additional front weight, #6250 –146A (not shown).

## WHEEL CLEANER ADJUSTMENT

- Unplug machine.
- Loosen wheel cleaner with 9/16" wrench (See Figure B).
- Slide cleaner up to face of wheel until it touches but DOES NOT dig into wheel surface.
- Retighten firmly.
- Over tightening wheel cleaner could cause damage to wheel.

**⚠ CAUTION:** Pinch Point.

## WHEEL REMOVAL

- Examine back of wheels (with a flashlight is helpful) to see if debris is built up.
- Keep clean from yarn build up.
- Unplug machine.
- Lay machine on its side.
- Use provided 3/16" allen wrench.
- Remove Axle Pin (new style only) (See Figure D).
- Remove wheel securing screw (See Figure C & D).
- Remove wheel securing cap.
- Wheel will slide off. Watch for keyway key. DO NOT LOSE.
- Remove wheel spacer. This should be inspected at regular intervals.

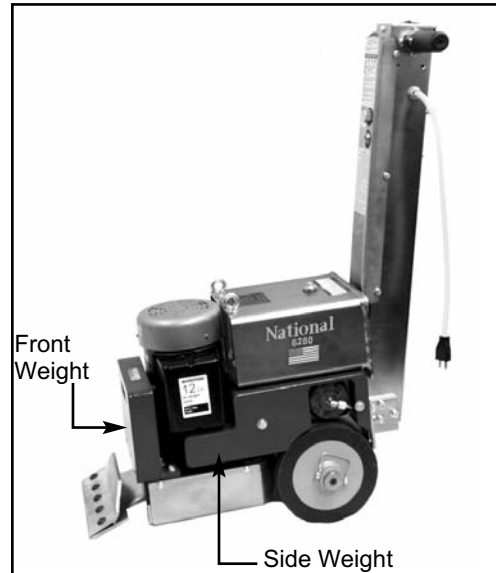

Figure A

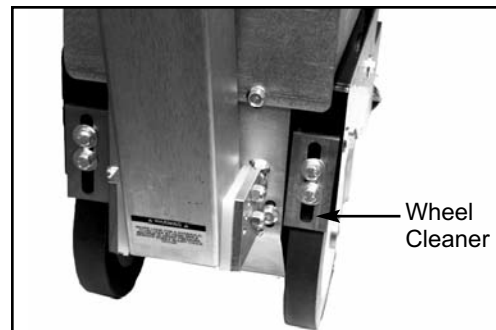
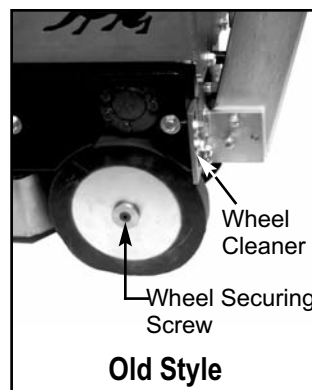
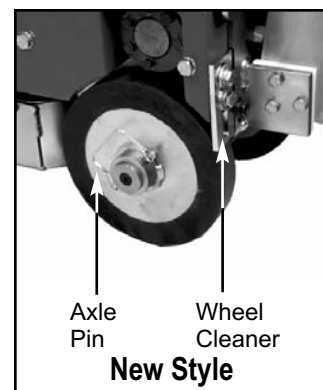

Figure B



Old Style

Figure C



New Style

Figure D

# 6280 PROCEDURES

## HYDRAULIC FLUID LEVEL

- Machine is run at a low temperature and pressure.
- Check fluid level if there has been a leak, damaged or ruptured hose or a loose fitting.
- Fluid level should be higher than the Return Line. See Figure A. Or from the Filler Port, 1" from the top of the tank (See Figure B).
- Machines have a fluid level sight window. See Figure A. The fluid should be in the middle to the top of the window when the machine is sitting in a normal operating position without a blade. If your machine does not have a sight window, fluid should be 1" from the top of the tank.

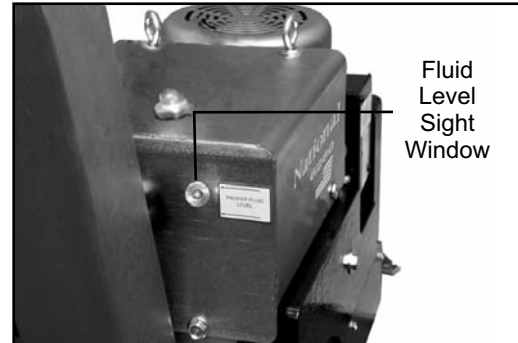

Figure A

## ADDING OR CHANGING HYDRAULIC FLUID

- Occasionally blow out the Filler Port Cap filter to remove debris.
- Change or add fluid only when needed.
- To add fluid, unscrew Filler Port Cap from top of machine (See Figure B).
- To change fluid, remove Filler Port Cap. Remove drain plug from side of machine (See Figure C). A container approximately two gallons in size will be needed to drain fluid into (fluid will not be removed from hoses).
- Machine has a straining system, but add fluid through a filter or funnel with a screen to keep fluid clean.
- Use Texaco Rando 46 Hydraulic Oil Light, stock #6280-1 or comparable.

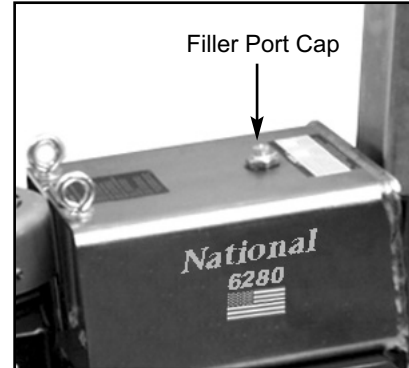

Figure B

## TANK REMOVAL

Removing the tank will be necessary to repair the pump or to replace or service internal hoses.

- Drain tank by removing top Filler Port Cap and Drain Plug on side of machine (See Figure C). A container approximately two gallons in size will be needed to drain fluid into.
- Replace Drain Plug and Filler Port Cap.
- Remove two lifting bail eyebolts and the two bolts from the back of the tank.
- Disconnect return line on back of tank, carefully lift tank 3" to 4" and disconnect suction line. Tank can now be removed.

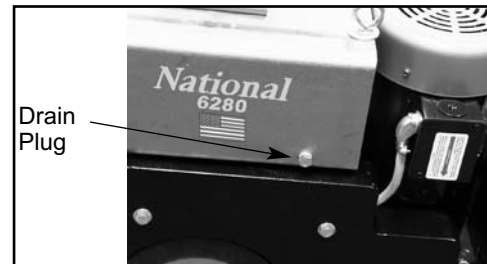

Figure C



# 6280 PROCEDURES

## INSPECTION OF INTERNAL PARTS

Visual inspection of internal parts can be done without draining tank.

- Remove two lifting bail eyebolts and the two bolts from the back of the tank.
- Carefully lift tank 3" to 4".
- Using a flashlight, inspect drive chain, hoses, front seal on motor, and suction and pressure line on pump.
- If service is necessary, follow procedure for tank removal.

## SPEED CONTROL

- Speed control knob can be adjusted while machine is running.
- Turning speed control knob counter clockwise will make machine run faster (See Figure C).
- Turning speed control knob clockwise will make machine run slower (See Figure C).

## SPEED CONTROL REPLACEMENT

- Use a 3/32" allen wrench to remove plastic knob.
- Use a 1" deep socket to remove and replace speed control valve.
- Re-install plastic knob.

## PRESSURE VALVE REPLACEMENT

This has been factory set and should not be tampered with.

- Use a 1" deep socket to remove old unit and install new.

## FORWARD AND REVERSE SWITCH REPLACEMENT

- Disconnect power source to unit.
- Remove 2 1/4 - 20 x 1/2 hexhead bolts from handle. Use 7/16 diameter wrench or socket.
- Loosen 9/16 nut that secures switch to handle.
- Remove handle and switch.
- Remove 2 spade connectors from switch.
- For switch replacement, bend the 2 prongs 90° from both ends of switch. Use old switch as a pattern.

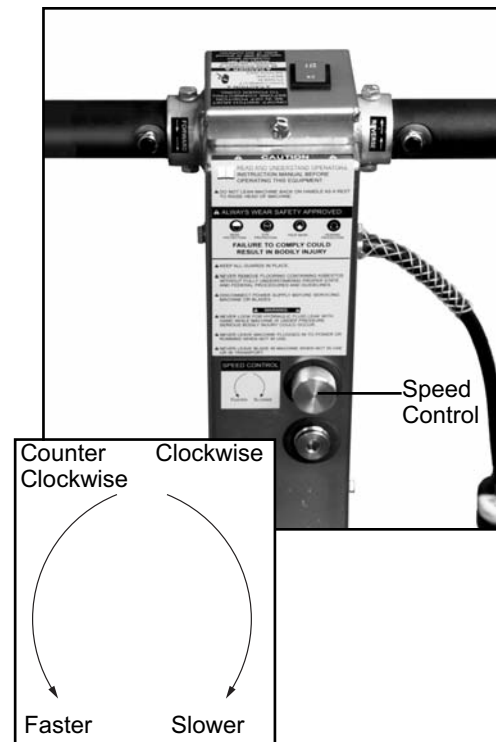

Figure C

# 6280 PROCEDURES

## FORWARD AND REVERSE SWITCH REPLACEMENT (continued)

- Connect 2 space connectors to 2 bent prongs on switch.
- Install black washer in new switch, and re-install switch in notch in handle. Tighten with a 9/16 wrench or socket. Use care not to strip threads.
- Insert handle into collar on handle column, and replace the 2 1/4 - 20 x 1 1/2 bolts. Tighten bolts with 7/16 wrench.

## CARTRIDGE REPLACEMENT

- Disconnect solenoid wires from switches.
- Remove nut on top of solenoid.
- Remove solenoids and spacer.
- Remove cartridge with a 1" wrench.
- Replace with new cartridge.
- Remount solenoids to make sure spacer is in between.
- Re-install nut with lock-tight (do not over Tighten).
- Reconnect solenoid wires.

## POWER CORD

- If power cord is damaged, it must be replaced by National or its service agent, or a similar qualified person in order to avoid a hazard.

## ON/OFF SWITCH WIRE DIAGRAM

- 2 power wires go to copper spades
- 2 other wires go to other spades

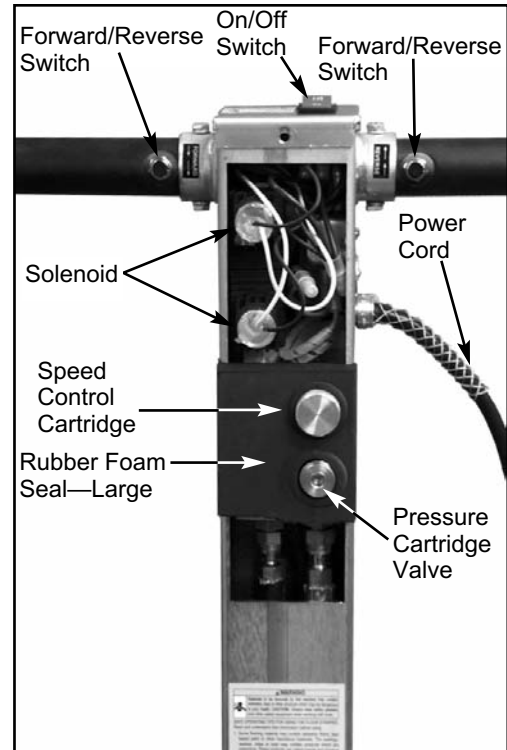

# 6280 TROUBLESHOOTING

## IF THERE IS NO FORWARD OR REVERSE:

1. Check speed control valve. Turn counterclockwise to open valve.
2. Check wheel pins. Make sure they are in the wheels.
3. Check belt. Remove front cover plate (#6280-145) and inspect.

## IF MOTOR SHUTS OFF OR WILL NOT START:

1. Push reset button located on electric box on motor, located on right hand side (See Figure A). See label on motor.

## IF WHEELS DO NOT TURN WHEN MACHINE IS UNDER POWER:

1. Make sure axle pins are in place.

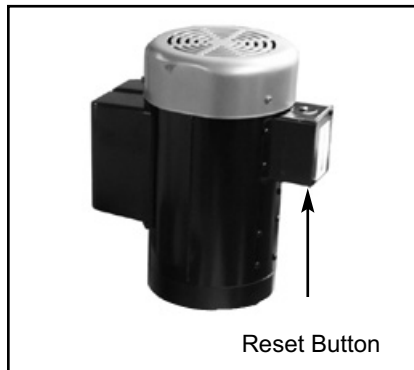

**Figure A**

**Note:** Number in parenthesis ( ) is the amount needed on each machine. Parts are sold individually. Be sure to order the number of parts needed.

# 6280 COMPLETE PARTS LIST

<u>PART #</u>	<u>DESCRIPTION</u>
6280-6	PUMP SHAFT KEY (NOT SHOWN)
6280-7	TANK MOUNTED STRAINER
6280-103	AXLE SHAFT (OLD STYLE)
6280-103-1	AXLE SHAFT (NEW STYLE)
6280-103A	AXLE SNAP RING (2)
6280-104	AXLE SPROCKET WITH KEY
6280-105L	AXLE BEARING SUPPORT LEFT
6280-105R	AXLE BEARING SUPPORT RIGHT
6280-107	BASE PLATE (2" ECCENTRIC HOLE)
6280-108	BASE PLATE (2¼" ECCENTRIC HOLE)
6280-110	WHEEL SPACER 1/2" (NOT SHOWN)
6280-111A	WHEEL KEY (NOT SHOWN)
6280-111-2B	WHEEL WITH HUB (NEW STYLE)
6280-112	WHEEL CAP (2)
6280-113	PUMP NON SPLINE (OLD STYLE)
6280-113A	HYDRAULIC PUMP KEY (OLD STYLE) (NOT SHOWN)
6280-113S	PUMP SPLINED (NEW STYLE)
6280-113-1	SEAL KIT (NOT SHOWN)
6280-114B	PUMP DRIVE ASSEMBLY - SPLINED
6280-114BN	PUMP DRIVE ASSEMBLY - NON-SPLINED
6280-115	PUMP SHEAVE ONLY
6280-116	PUMP SHAFT NON SPLINE (OLD STYLE)
6280-116A	PUMP SHAFT SPLINED (NEW STYLE)
6280-117	PRESSURE HOSE TO PUMP CONNECTOR
6280-118	SUCTION HOSE TO PUMP CONNECTOR
6280-119	PUMP SPACER
6280-120	SUCTION HOSE
6280-124	PUMP DRIVE BELT
6280-125	IDLER ASSEMBLY COMPLETE (INCLUDES 125A, 126, 126A, 73003,73210, 73218) (NOT SHOWN)
6280-125A	IDLER MOUNTING BRACKET & PIN
6280-126A	IDLER BEARING CAP
6280-129C	ECCENTRIC KEY
6280-132	BEARING CUP ONLY (OLD STYLE)
6280-132B	CUP BEARING WITH BEARING ASSEMBLY (OLD STYLE)
6280-133	CUTTING HEAD VIBRATION ISOLATOR (5)
6280-134	CUTTING HEAD (OLD STYLE)
6280-135	CUTTING HEAD BEARING ASSEMBLY (OLD STYLE)
6280-136	BLADE COVER
6280-138	MAIN BOTTOM COVER (NEW STYLE)
6280-138E	MAIN BOTTOM COVER (OLD STYLE)
6280-139	REAR COVER
6280-143	CUTTING HEAD (NEW STYLE)
6280-145	FRONT COVER
6280-146	FRONT COUNTERWEIGHT
6280-147-1	STARTER SWITCH
6280-147-3	THERMO OVERLOAD SWITCH
6280-148	MOTOR FAN COVER
6280-148A	MOTOR FAN COVER SCREW 8-32 X 3/8 HEX WASHER HEAD TORX DR. SS (3)
6280-149	MOTOR FAN (NOT SHOWN)
6280-150	CAPACITOR COVER
6280-150A	CAPACITOR COVER SCREWS (2) (NOT SHOWN)
6280-151A	MOTOR CAPACITOR (RUN)
6280-151B	MOTOR CAPACITOR (START)

# 6280 COMPLETE PARTS LIST

## PARTS (continued)

<u>PART #</u>	<u>DESCRIPTION</u>
6280-152	MOTOR JUNCTION BOX ONLY
6280-152-1	MOTOR JUNCTION BOX COVER ONLY
6280-152-2	MOTOR JUNCTION BOX & COVER SECURING SCREW (4/BOX, 2/COVER) (NOT SHOWN)
6280-152-3	COVER GASKET ONLY
6280-152-4	JUNCTION BOX FRAME GASKET ONLY
6280-153L	LEFT UPPER MAIN BODY
6280-153R	RIGHT UPPER MAIN BODY
6280-155L	LEFT UPPER MAIN BODY (NEW STYLE)
6280-161A	FILLER CAP BUSHING ONLY (OLD STYLE)
6280-161B	FILLER CAP VENT PLUG ONLY (OLD STYLE)
6280-161C	FILLER PORT PLUG ASSEMBLY - TAPERED THREAD (OLD STYLE)
6280-161D	FILLER PORT PLUG ASSEMBLY - STRAIGHT THREAD (NEW STYLE)
6280-162	HYDRAULIC TANK BODY
6280-162E	DRAIN PLUG/OIL LEVEL
6280-162G	TANK MAGNET (NOT SHOWN)
6280-163	HYDRAULIC TANK COVER (OLD STYLE) (NOT SHOWN)
6280-163A	HYDRAULIC TANK COVER GASKET (NOT SHOWN)
6280-165	WHEEL CLEANER
6280-166B	SWITCH PLATE CAP
6280-166C	HANDLE COVER PLATE
6280-166D	RUBBER FOAM SEAL, LARGE
6280-166E	RUBBER FOAM SEAL, SMALL (2)
6280-167	HANDLE BODY
6280-167D	HANDLE VIBRATION ISOLATOR (2)
6280-168	POWER CORD (NEW STYLE)
6280-170	HANDLE BAR (2)
6280-170A	HANDLE BAR GRIPS (2)
6280-175	HUBBLE TWIST LOCK FEMALE PLUG 110 VOLT (INSIDE HANDLE BODY) (NOT SHOWN)
6280-176	HUBBLE TWIST LOCK MALE PLUG 110 VOLT (INSIDE HANDLE BODY)
6280-177	3/8 90° CABLE CONNECTOR
6280-178	POWER CORD STRAIN RELIEF
6280-179	MOTOR SPACER RING
6280-180	MOTOR HOSE
6280-181	PRESSURE HOSE
6280-182	RETURN LINE HOSE
6280-206	FORWARD/REVERSE SWITCH (2)
6280-206B	SWITCH CAP
6280-207	ON/OFF SWITCH 110 VOLT
6280-208	SPEED CONTROL CARTRIDGE
6280-208A	SPEED CONTROL KNOB ONLY
6280-209	PRESSURE CARTRIDGE VALVE
6280-212	RETURN LINE
6280-214	BLOCK PLUG (NOT SHOWN)
6280-215	VALVE BLOCK ASSEMBLY
6280-216	SOLENOID VALVE CARTRIDGE
6280-217	SOLENOID COILS 110V (2)
6280-219	VALVE BODY PLUG (NOT SHOWN)
6280-220	HYDRAULIC MOTOR (OLD STYLE)
6280-220A	HYDRAULIC MOTOR (NEW STYLE)
6280-221	HYDRAULIC MOTOR CONNECTOR (2)
6280-223	HYDRAULIC MOTOR SHAFT KEY
6280-224	HYDRAULIC MOTOR SPROCKET
6280-225	HYDRAULIC MOTOR SPACER

# 6280 COMPLETE PARTS LIST

## PARTS (continued)

<u>PART #</u>	<u>DESCRIPTION</u>
6280-226	HYDRAULIC MOTOR MOUNTING BRACKET
6280-228	DRIVE CHAIN
6280-229	DRIVE CHAIN MASTER LINK ASSEMBLY
6280-230	SIDE COUNTERWEIGHT RIGHT
6280-231	SIDE COUNTERWEIGHT LEFT
6280-304	DRAIN HOSE
6280-400	ECCENTRIC ONLY (NEED KEY & SET SCREWS) (OLD STYLE)
6280-400A	ECCENTRIC ASSEMBLY COMPLETE (OLD STYLE) (INCLUDES 129C, 400, 73010, 73012 [2]) (NOT SHOWN)
6280-401	BLADE SOCKET HEXHEAD WRENCH (OLD STYLE)
6280-401B	BLADE ALLEN BUTTON HEAD WRENCH (NEW STYLE)
6280-404	BLADE WRENCH HOLDER
6280-405	ECCENTRIC ONLY, NEED KEY & SET SCREWS (NEW STYLE)
6280-405A	ECCENTRIC ASSEMBLY COMPLETE (NEW STYLE) (INCLUDES 131, 405,73010, 72012 [2]) (NOT SHOWN)
6280-1151	PUMP SHEAVE RETAINER ONLY
6280-1152A	PUMP SHAFT SNAP RING
6280HD-131	ECCENTRIC KEY
6280HD-146	FRONT COUNTERWEIGHT
62504	FILLER PORT "O" RING (OLD STYLE)
71072	IDLER BEARING (2)
71093	CUP BEARING (OLD STYLE)
71113	WHEEL BEARING (NEW STYLE) (NOT SHOWN)
71115	1 X 2 X 1/2 BEARING (AXLE-2, PUMP DRIVE-1, HYD MOTOR-1, ECCENTRIC-1)
71118	FLANGE BEARING
71132	ECCENTRIC BEARING
71141	CUTTING HEAD BEARING ASSEMBLY 1-7/16 (NEW STYLE)
72364	MOTOR 115 VOLT (OLD STYLE, 7/8" SHAFT)
72365	MOTOR 115 VOLT (NEW STYLE, 1-1/8" SHAFT)
72367W	MOTOR 230 VOLT, 1.5 HP MOTOR (NEW STYLE)
72368W	MOTOR 220 VOLT, 1.5 HP MOTOR (OLD STYLE) (#115753)
72816	RETURN LINE ELBOW
73002	1/4 SPLIT LOCK WASHER (PUMP DRIVE ASSEMBLY-3, REAR VIEW EXTERNAL-13 [NOT SHOWN], HANDLE-10)
73003	1/4-20 X 5/8 BUTTON HEAD CAP SCREW
73005	1/4-20 X 1/2 HEXHEAD BOLT (4)
73008	1/4-20 NYLON LOCK NUT (OLD STYLE) (4)
73010	1/4-20 X 1/4 SET SCREW (ECCENTRIC ASSEMBLY-1, AXLE ASSEMBLY-1)
73012	1/4-20 X 3/8 SET SCREW (ECCENTRIC ASSEMBLY-2, AXLE ASSEMBLY-1)
73015	1/4-20 X 1-3/8 HEXHEAD BOLT, GRADE 5 (3)
73019	1/4-20 X 3/4 HEXHEAD BOLT (4)
73020	1/4-20 X 5/8 WIZLOCK BOLT (EXTERNAL PARTS-8, BODY PARTS-2)
73022	1/4-28 X 1/2 HEXHEAD BOLT, GRADE 5 (REAR VIEW EXTERNAL-8, HANDLE-8)
73024	1/4-20 X 5/8 LOW HEAD CAP SCREW (8) (OLD STYLE) (NOT SHOWN)
73033	1/4 X 1/4 X 1 KEY
73101	1/8 SPACER
73201	3/8-16 X 1 HEXHEAD BOLT, GRADE 5 (BASE PLATE-4, WHEEL CLEANER-1, )
73203	3/8 FLAT WASHER (EXTERNAL PARTS-4 [NOT SHOWN], BOTTOM COVER -2, WHEEL CLEANER-2, BODY PARTS-1 [NOT SHOWN], INTERNAL-3)
73204	3/8 SPLIT WASHER (EXTERNAL PARTS-4 [NOT SHOWN], BASE PLATE-4, WHEEL CLEANER-3, INTERNAL-3)
73217	3/8-16 X 3/4 LOWHEAD SOCKET BOLT (EXTERNAL PARTS-5 [OLD STYLE], BASE PLATE-5)
73206	3/8-16 X 1-1/4 HEXHEAD BOLT, GRADE 8 (REAR VIEW EXTERNAL: NEW STYLE-6 OLD STYLE-4, INTERNAL-3)
73210	3/8 EXTERNAL LOCK WASHER
73211	3/8-16 WIZLOCK NUT (BASE PLATE-5, BOTTOM COVER-2)
73213	3/8-16 X 3/4 BUTTON HEAD CAP SCREW (5) (NEW STYLE) (NOT SHOWN)
73218	3/8-24 X 3/4 HEXHEAD BOLT, GRADE 5
73221	3/8-16 X 2-3/4 HEXHEAD BOLT (4)

# 6280 COMPLETE PARTS LIST

## PARTS (continued)

<u>PART #</u>	<u>DESCRIPTION</u>
73222	3/8-16 X 1 WIZLOCK BOLT ( MOTOR PARTS-2, INTERNAL PARTS-4)
73223	3/8-16 X 1-1/4 WIZLOCK BOLT (MOTOR PARTS-2, INTERNAL PARTS-2)
73224	3/8-16 X 1/2 WIZLOCK BOLT (4)
73226	3/8-24 X 1 HEXHEAD BOLT (4)
73228	3/8-16 X 8 EYEBOLT (2)
73235	3/8-24 JAMB NUT (4) (NOT SHOWN)
73242	3/8-16 X 1 BUTTON HEAD CAP SCREW W/ FLANGE (NEW STYLE) (5)
73245	3/8-16 X 1½ WIZLOCK FLANGE BOLT (2)
73301	5/16-18 X 1/2 BUTTON HEAD CAP SCREW (3) (NOT SHOWN)
73304	5/16 WAVEY WASHER (2)
73309	5/16-18 X 3/4 SOCKET HEAD CAP SCREW (4)
73310	5/16-18 X 7/8 SOCKET HEAD CAP SCREW, RIGHT, GRADE 5 (2)
73311	5/16-18 X 1 SOCKET HEAD CAP SCREW, LEFT, GRADE 5 (2)
73313	5/16-18 X 1/2 FLAT HEAD SOCKET CAP SCREW (NEW STYLE) (2)
73315	5/16-18 X 1 FLAT HEAD ALLEN SCREW (OLD STYLE) (2)
73330	5/16 X 2 PIN
73332	5/16 X 18-5/8 HEXHEAD BOLT (2)
74402	10-32 X 3/8 CUP POINT SET SCREW (SPEED CONTROL) (NOT SHOWN)

## ACCESSORIES

<u>PART #</u>	<u>DESCRIPTION</u>
6251	LOADING RAMP
6251-1	REPLACEMENT PINCH POINT GUARD (SET)
6254	50' 12 GAUGE POWER CORD
6254-1	FEMALE CONNECTOR ONLY, 4729C
6254-2	MALE PLUG ONLY, 5266C
6280-1	HYDRAULIC FLUID, GALLON (NOT SHOWN)
6280-146A	ADDITIONAL FRONT WEIGHT
6280-299	FRONT TRANSPORT WHEEL ASSEMBLY
6280-300	TRANSPORT WHEEL BRACKET (NOT SHOWN)
6280-301	FRONT TRANSPORT WHEEL ONLY
6280-500	SWIVEL HEAD ATTACHMENT
6280-502	OPTIONAL SADDLE WEIGHT
73219	3/8-16 X 5 HEXHEAD BOLT (FOR 2 ADDITIONAL WEIGHTS)
73220	3/8-16 X 3 HEXHEAD BOLT (FOR 1 ADDITIONAL WEIGHT)

## BLADES

<u>PART #</u>	<u>DESCRIPTION</u>
130-S	3" X 10" BLADE WITH SLOTS
130-D	3" X 10" DOUBLE EDGE BLADE
131-S	3" X 16" BLADE WITH SLOTS
135	5" X 16" BLADE
136	5" X 8" BLADE
147	4" X 6" BLADE
147-D	4" X 6" DOUBLE EDGE BLADE
148	5" X 6" BLADE
148-D	5" X 6" DOUBLE EDGE BLADE
363-2	3/4" X 8" SCRAPER BLADE (50/PKG)
368-8	7/8" X 8" RAZOR/SCRAPER BLADE (50/PKG)
368-12	7/8" X 12" RAZOR/SCRAPER BLADE (50/PKG)



# 6280 COMPLETE PARTS LIST

## BLADES (continued)

<u>PART #</u>	<u>DESCRIPTION</u>
368-15	7/8" X 15" RAZOR/SCRAPER BLADE (50/PKG)
6253	PANTHER RIPPER TEETH
6255-BU	4" X 6" SELF SCORING BLADE
6257-BU	3" X 9" SELF SCORING BLADE
6258-BU	3" X 12" SELF SCORING BLADE
6259-BU	3" X 14" SELF SCORING BLADE
6277-BU	3" X 12" SELF SCORING BLADE
6278-BU	3" X 14" SELF SCORING BLADE
6270	1-1/2" X 3" EXTRA HEAVY DUTY BLADE
6271	3" X 6" EXTRA HEAVY DUTY BLADE
6273	3" X 11" EXTRA HEAVY DUTY BLADE
6280-500	SWIVEL HEAD ATTACHMENT
6281	3" X 8" HEAVY DUTY BLADE
6282	3" X 14" HEAVY DUTY BLADE
6284	3" X 12" HEAVY DUTY BLADE
6285	3" X 6" HEAVY DUTY BLADE
6286	3" X 10" HEAVY DUTY BLADE
6290	3" X 6" EXTRA HEAVY DUTY BLADE
6291	3" X 8" EXTRA HEAVY DUTY BLADE
6292	3" X 12" EXTRA HEAVY DUTY BLADE
6293	3" X 14" EXTRA HEAVY DUTY BLADE
7050-200	3" X 6" PREMIUM HIGH TEMP BLADE
7050-201	3" X 8" PREMIUM HIGH TEMP BLADE
7050-202	3" X 10" PREMIUM HIGH TEMP BLADE
7050-203	3" X 12" PREMIUM HIGH TEMP BLADE
7050-204	3" X 14" PREMIUM HIGH TEMP BLADE
7080	3" X 8" INCREASED ANGLE BLADE
7081	3" X 10" INCREASED ANGLE BLADE

## LABELS

<u>PART #</u>	<u>DESCRIPTION</u>
L37	CAUTION SHARP BLADE LABEL
L49	POWER CORD LABEL
L95B	ON/OFF SWITCH LABEL
L95C	FORWARD LABEL
L95D	REVERSE LABEL
L95E	SPEED CONTROL LABEL
L95F	WARNING FLUID LEAK LABEL
L95G	FLUID LEVEL LABEL
L95H	CAUTION DO NOT RUN LABEL
L95J	110 VOLT LABEL
L95K	RAMP LABEL (2)
L95L	REMOVE COUNTERWEIGHTS LABEL
L141	MADE IN USA LABEL
L173B	STOCK NUMBER LABEL
L175	NATIONAL LABEL, SMALL (2)
L188	CAUTION GENERAL INFO LABEL
L189	SAFE OPERATING TIPS LABEL
L223	PATENT NUMBER LABEL



# 6280 PART NUMBERS & DIAGRAMS

## REAR VIEW EXTERNAL PARTS

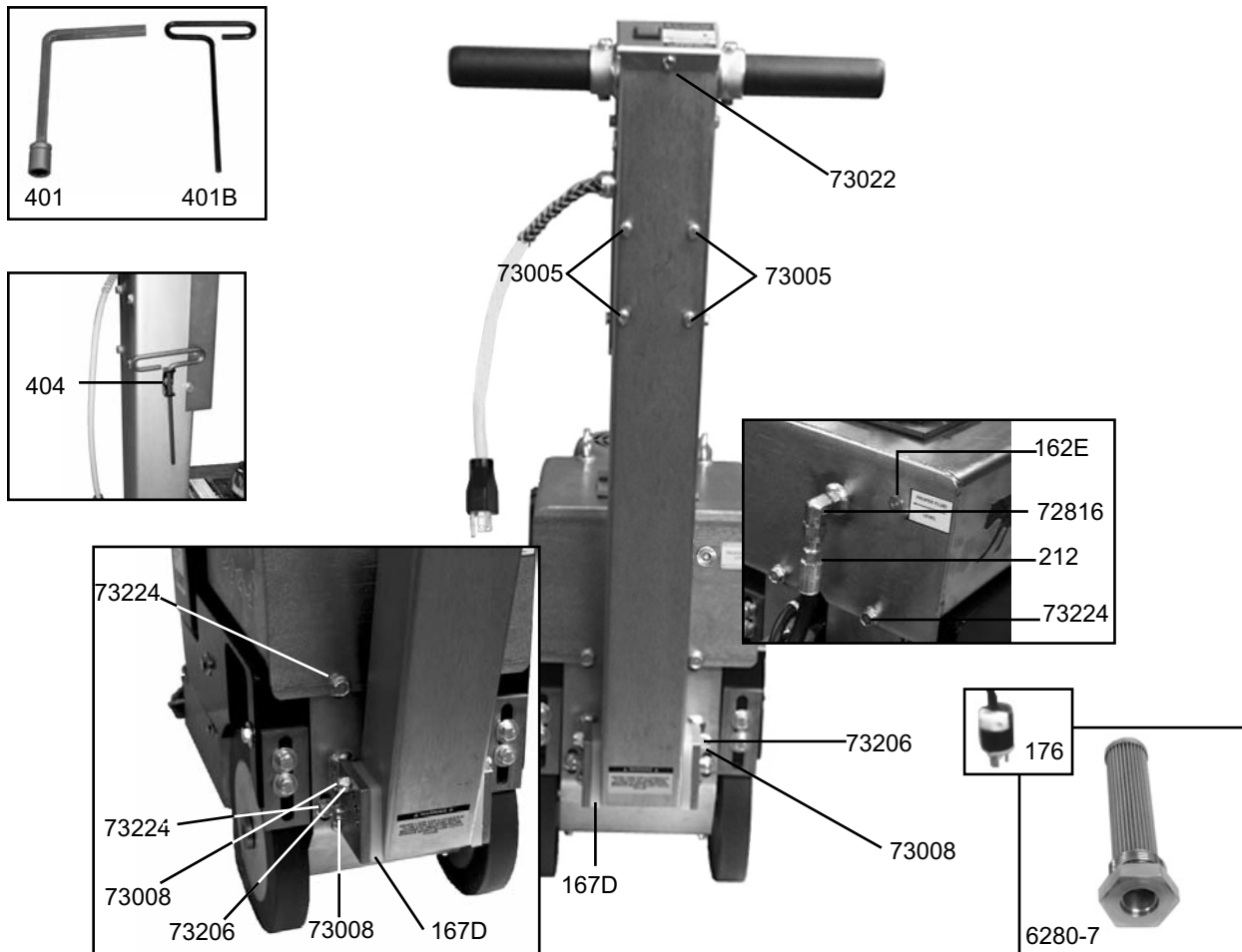

<b>PART #</b>	<b>DESCRIPTION</b>	<b>PART #</b>	<b>DESCRIPTION</b>
6280-7	Tank Mounted Strainer	6280-401B	Blade Allen Button Head Wrench (New Style)
6280-162E	Drain Plug/Oil Level	6280-404	Blade Wrench Holder
6280-163A	Hydraulic Tank Cover Gasket (Not Shown)	72816	Return Line Elbow
6280-167D	Handle Vibration Isolator (2)	73002	1/4 Split Lock Washer (13) (Not Shown)
6280-175	Hubble Twist Lock Female Plug 110V (Inside Handle Body) (Not Shown)	73005	1/4-20 x 1/2 Hexhead Bolt (4)
6280-176	Hubble Twist Lock Male Plug 110V (Inside Handle Body)	73008	1/4-20 Nylon Lock Nut (Old Style) (4)
6280-212	Return Line	73022	1/4-28 x 1/2 Hexhead Bolt, Grade 5 (8)
6280-401	Blade Socket Hexhead Wrench (Old Style)	73206	3/8-16 x 1-1/4 Hexhead Bolt, Grade 8 New Style (6) Old Style (4)
		73224	3/8-16 x 1/2 Wizlock Bolt (4)

# 6280 PART NUMBERS & DIAGRAMS

## BASE PLATE PARTS

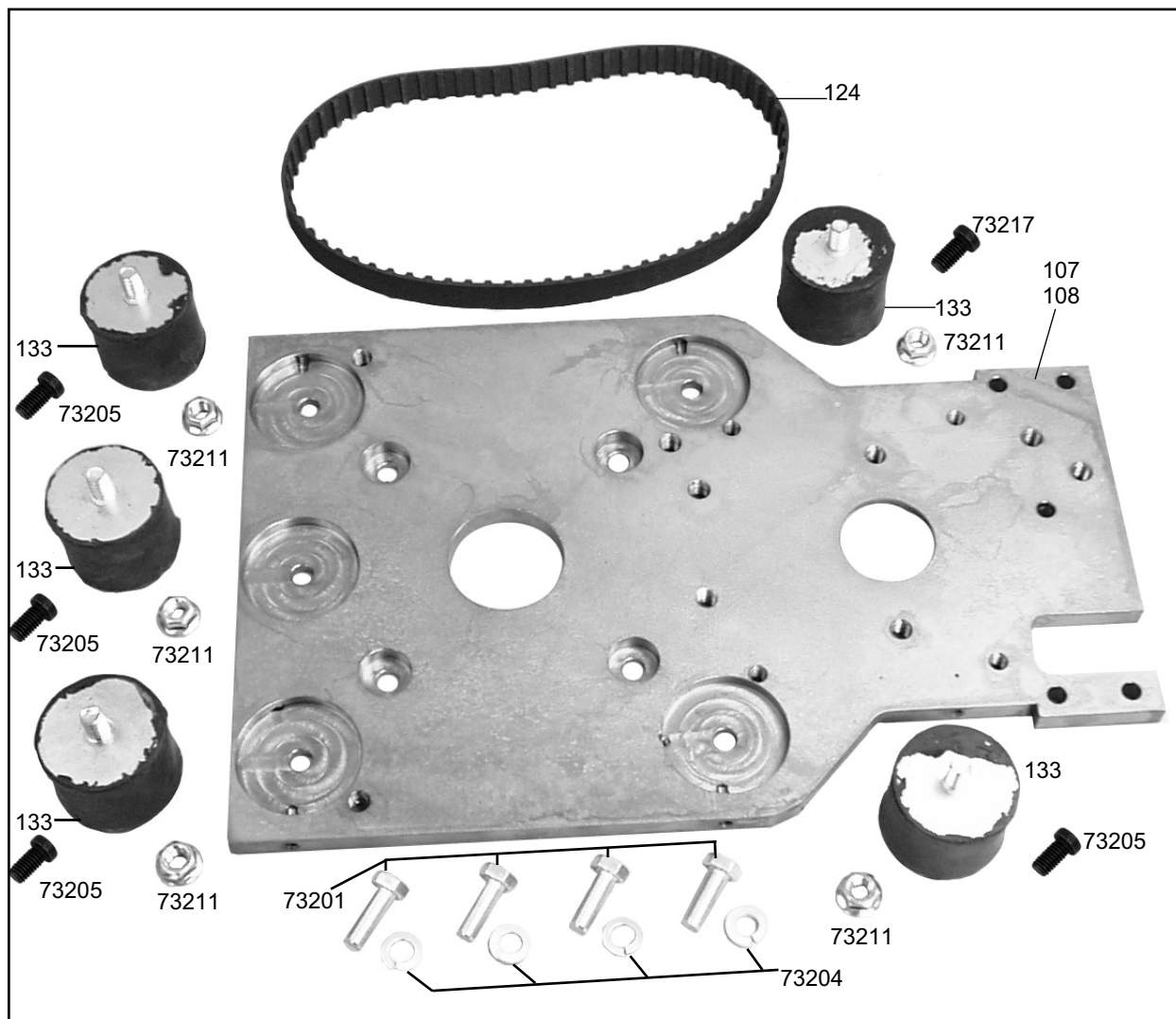

<u>PART #</u>	<u>DESCRIPTION</u>	<u>PART #</u>	<u>DESCRIPTION</u>
6280-107	Base Plate (2" Eccentric Hole)	73201	3/8-16 x 1 Hexhead Bolt, Grade 5 (4)
6280-108	Base Plate (2 1/4" Eccentric Hole)	73204	3/8 Split Lock Washer (4)
6280-124	Pump Drive Belt	73217	3/8-16 x 3/4 Lowhead Bolt (5)
6280-133	Cutting Head Vibration Isolator (5)	73211	3/8-16 Wizlock Nut (5)

# 6280 PART NUMBERS & DIAGRAMS

## IDLER ASSEMBLY PARTS



<u>PART #</u>	<u>DESCRIPTION</u>
6280-125	Idler Assembly Complete (Includes 125A, 126, 126A, 73003, 73218, 73210) (Not Shown)
6280-125A	Idler Mounting Bracket & Pin
6280-126A	Idler Bearing Cap
71072	Idler Bearing (2)
73003	1/4-20 x 5/8 Button Head Cap Screw
73210	3/8 External Lock Washer
73218	3/8-24 x 3/4 Hexhead Bolt, Grade 5

## PUMP DRIVE ASSEMBLY PARTS

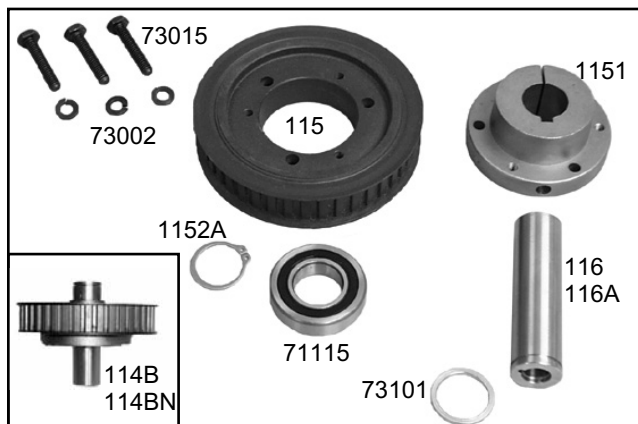

<u>PART #</u>	<u>DESCRIPTION</u>
6280-6	Pump Shaft Key (Not Shown)
6280-114B	Pump Drive Assembly- Splined
6280-114BN	Pump Drive Assembly- Non-Splined
6280-115	Pump Sheave Only
6280-116	Pump Shaft Non Spline (Old Style)
6280-116A	Pump Shaft Splined (New Style)
6280-1151	Pump Sheave Retainer Only
6280-1152A	Pump Shaft Snap Ring
71115	1 x 2 x 1/2 Bearing
73101	1/8 Spacer
73002	1/4 Split Lock Washer (3)
73015	1/4-20 x 1-3/8 Hexhead Bolt, Grade 5 (3)

## ECCENTRIC ASSEMBLY PARTS

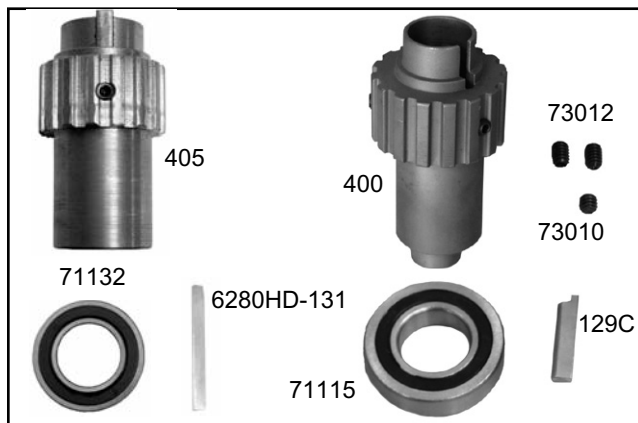

<u>PART #</u>	<u>DESCRIPTION</u>
6280-129C	Eccentric Key
6280-400	Eccentric Only, Need Key & Set Screws (Old Style)
6280-400A	Eccentric Assembly Complete (Old Style) (Includes 129C, 400, 73010, 73012 [2] ) (Not Shown)
6280-405	Eccentric Only, Need Key & Set Screws (New Style)
6280-405A	Eccentric Assembly Complete (New Style) (Includes 131, 405, 73010, 72012 [2] )(Not Shown)
6280HD-131	Eccentric Key
71115	1 x 2 x 1/2 Bearing
71132	Eccentric Bearing
73010	1/4-20 x 1/4 Set Screw
73012	1/4-20 x 3/8 Set Screw (2)

# 6280 PART NUMBERS & DIAGRAMS

## BEARING & BOTTOM COVER PARTS

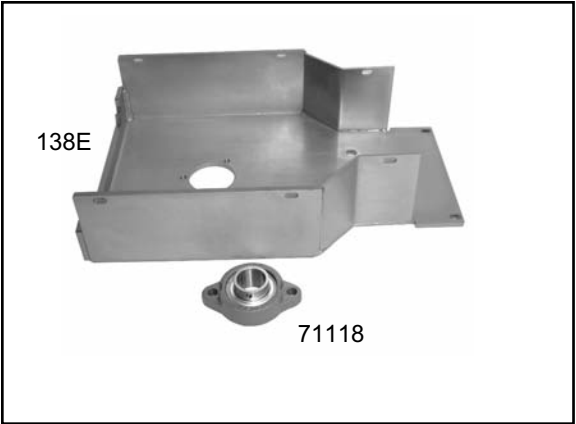
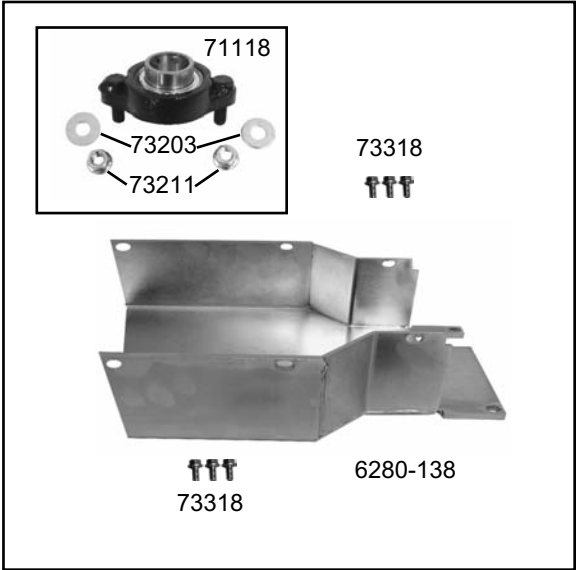
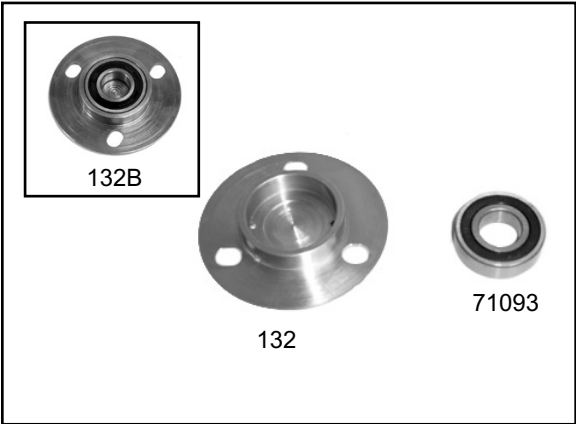

<b>PART #</b>	<b>DESCRIPTION</b>
6280-132	Bearing Cup Only (Old Style)
6280-132B	Cup Bearing w/Bearing Assembly (Old Style)
6280-138	Main Bottom Cover (New Style)
6280-138E	Main Bottom Cover (Old Style)
71093	Cup Bearing (Old Style)

<b>PART #</b>	<b>DESCRIPTION</b>
71118	Flange Bearing
73203	3/8 Flat Washer (2)
73211	3/8-16 Wizlock Nut (2)
73301	5/16-18 x 1/2 Button Head Cap Screw (3) (Not Shown)
73318	5/16-18 x 5/8 Wizlock Bolt (Bottom Cover -6)

# 6280 PART NUMBERS & DIAGRAMS

## AXLE ASSEMBLY PARTS



<u>PART #</u>	<u>DESCRIPTION</u>
6280-103	Axle Shaft (Old Style)
6280-103-1	Axle Shaft (New Style)
6280-103A	Axle Snap Ring (2)
6280-104	Axle Sprocket with Key
6280-105L	Axle Bearing Support Left
6280-105R	Axle Bearing Support Right
71115	1 x 2 x 1/2 Bearing (2)
73010	1/4-20 x 1/4 Set Screw
73012	1/4-20 x 3/8 Set Screw
73033	1/4 x 1/4 x 1 Key
73310	5/16-18 x 7/8 Socket Head Cap Screw, Right, Grade 5 (2)
73311	5/16-18 x 1 Socket Head Cap Screw, Left, Grade 5 (2)

## WHEEL CLEANER PARTS

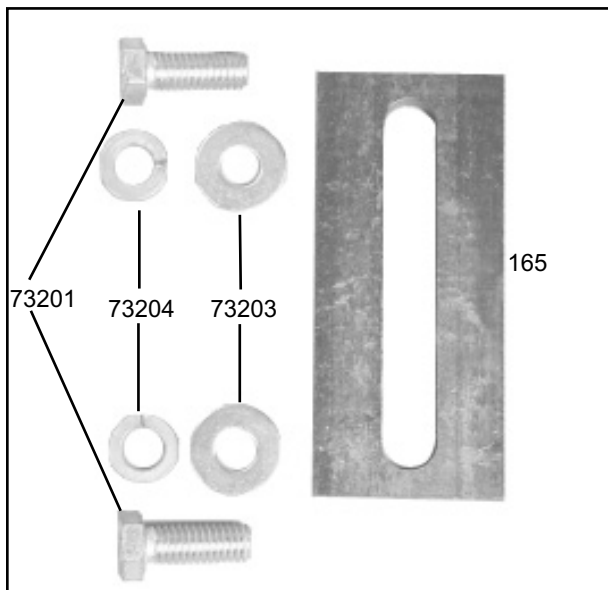

<u>PART #</u>	<u>DESCRIPTION</u>
6280-165	Wheel Cleaner
73201	Wheel Cleaner Hexhead Bolt 3/8-16 X 1, Grade 5 (2)
73203	3/8 Flat Washer (2)
73204	3/8 Split Washer (2)

# 6280 PART NUMBERS & DIAGRAMS

## INTERNAL HANDLE PARTS

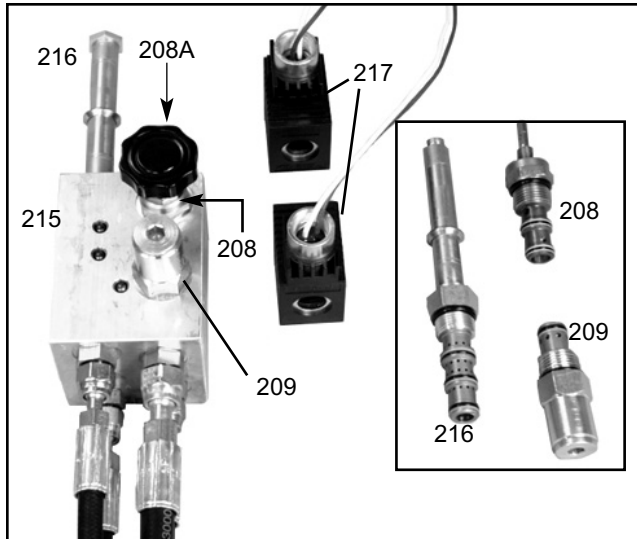

## HOSE PARTS

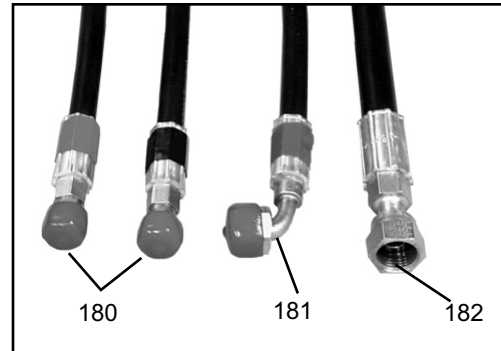

## HANDLE PARTS

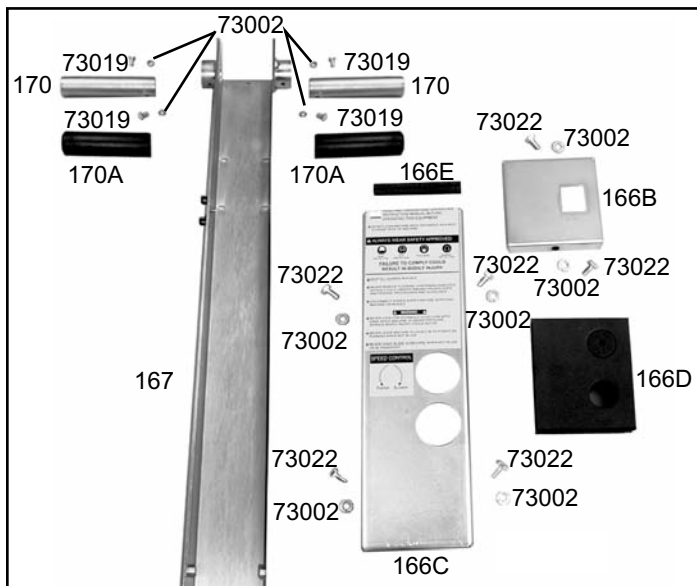

<b>PART #</b>	<b>DESCRIPTION</b>
6280-166B	Switch Plate Cap
6280-166C	Handle Cover Plate
6280-166D	Rubber Foam Seal, Large
6280-166E	Rubber Foam Seal, Small
6280-167	Handle Body
6280-170	Handle Bar (2)
6280-170A	Handle Bar Grips (2)
6280-180	Motor Hose
6280-181	Pressure Hose
6280-182	Return Line Hose
6280-208	Speed Control Cartridge
6280-208A	Speed Control Knob Only
6280-209	Pressure Cartridge Valve
6280-214	Block Plug (Not Shown)
6280-215	Valve Block Assembly
6280-216	Solenoid Valve Cartridge
6280-217	Solenoid Coils 110V (2)
6280-219	Valve Body Plug (Not Shown)
73002	1/4 Split Washer (10)
73019	1/4-20 x 3/4 Hexhead Bolt (4)
73022	1/4-28 x 1/2 Hexhead Bolt, Grade 5 (8)
74402	10-32 x 3/8 Cup Point Set Screw (Speed Control) (Not Shown)



# 6280 PART NUMBERS & DIAGRAMS

## MOTOR PARTS

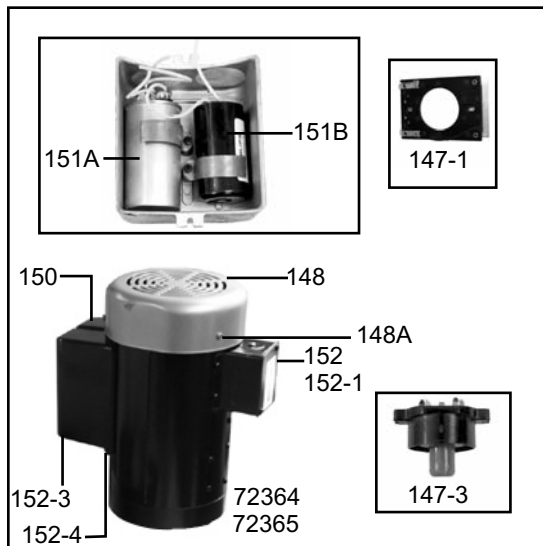

## BODY PARTS

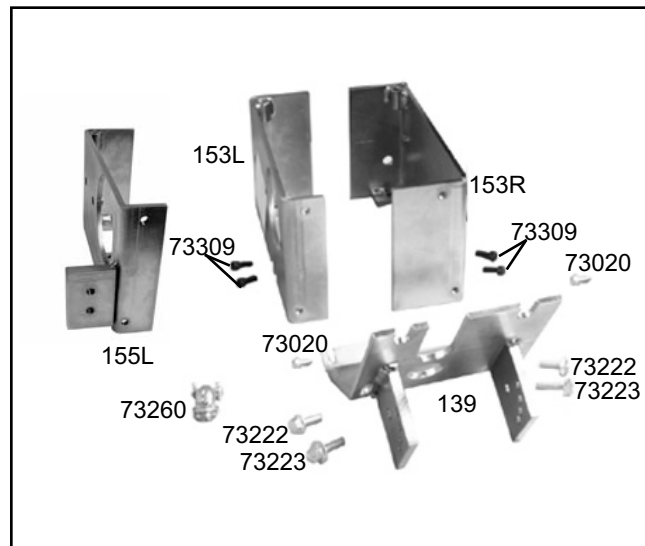

<u>PART #</u>	<u>DESCRIPTION</u>
6280-139	Rear Cover
6280-147-1	Starter Switch
6280-147-3	Thermo Overload Switch
6280-148	Motor Fan Cover
6280-148A	Motor Fan Cover Screw 8-32 x 3/8 Hex Washer Head Torx Dr. SS (3)
6280-149	Motor Fan (Not Shown)
6280-150	Capacitor Cover
6280-150A	Capacitor Cover Screws (2) (Not Shown)
6280-151A	Motor Capacitor (Run)
6280-151B	Motor Capacitor (Start)
6280-152	Motor Junction Box Only
6280-152-1	Motor Junction Box Cover Only
6280-152-2	Motor Junction Box & Cover Securing Screw (4/box, 2/cover) (Not Shown)
6280-152-3	Cover Gasket Only

<u>PART #</u>	<u>DESCRIPTION</u>
6280-152-4	Junction Box Frame Gasket Only
6280-153L	Left Upper Main Body
6280-153R	Right Upper Main Body
6280-155L	Left Upper Main Body (New Style)
72364	Motor 115 Volt, 1.5 HP (Old Style, 7/8" Shaft) (#115919)
72365	Motor 115 Volt, 1.5 HP (New Style, 1-1/8" Shaft) (#116944)
72367W	Motor 230 Volt, 1.5 HP (New Style)
72368W	Motor 220 Volt, 1.5 HP (Old Style) (#115753)
73020	1/4-20 x 5/8 Wizlock Bolt (2)
73203	3/8 Flat Washer (Not Shown)
73222	3/8-16 x 1 Wizlock Bolt (2)
73223	3/8-16 x 1-1/4 Wizlock Bolt (2)
73260	3/8 90° Cable Connector
73309	5/16-18 x 3/4 Socket Head Cap Screw (4)

# 6280 PART NUMBERS & DIAGRAMS

## SWITCH PARTS

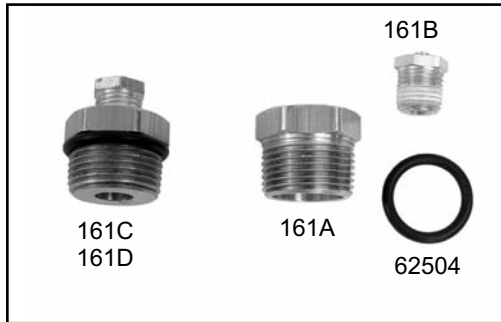

## CUTTING HEAD PARTS

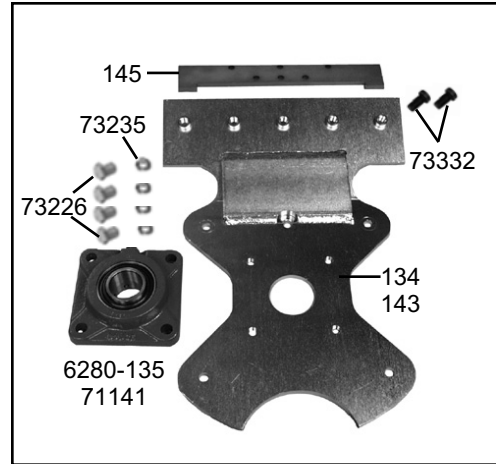

<u>PART #</u>	<u>DESCRIPTION</u>
6280-134	Cutting Head (Old Style)
6280-135	Cutting Head Bearing Assembly (Old Style)
6280-143	Cutting Head (New Style)
6280-145	Front Cover
6280-161A	Filler Cap Bushing Only (Old Style)
6280-161B	Filler Cap Vent Plug Only
6280-161C	Filler Port Plug Assembly-Tapered Thread (Old Style)
6280-161D	Filler Port Plug Assembly-Straight Thread (New Style)

<u>PART #</u>	<u>DESCRIPTION</u>
6280-206	Forward/Reverse Switch (2)
6280-206B	Switch Cap
6280-207	On/Off Switch 110 Volt
62504	Filler Port "O" Ring (Old Style)
71141	1-7/16 Cutting Head
	Bearing Assembly (New Style)
73226	3/8-24 x 1 Hexhead Bolt (4)
73235	3/8-24 Jamb Nut (4)
73304	5/16 Wavy Washer (2)
73332	5/16 x 18-5/8 Hexhead Bolt (2)

# 6280 PART NUMBERS & DIAGRAMS

## INTERNAL PARTS

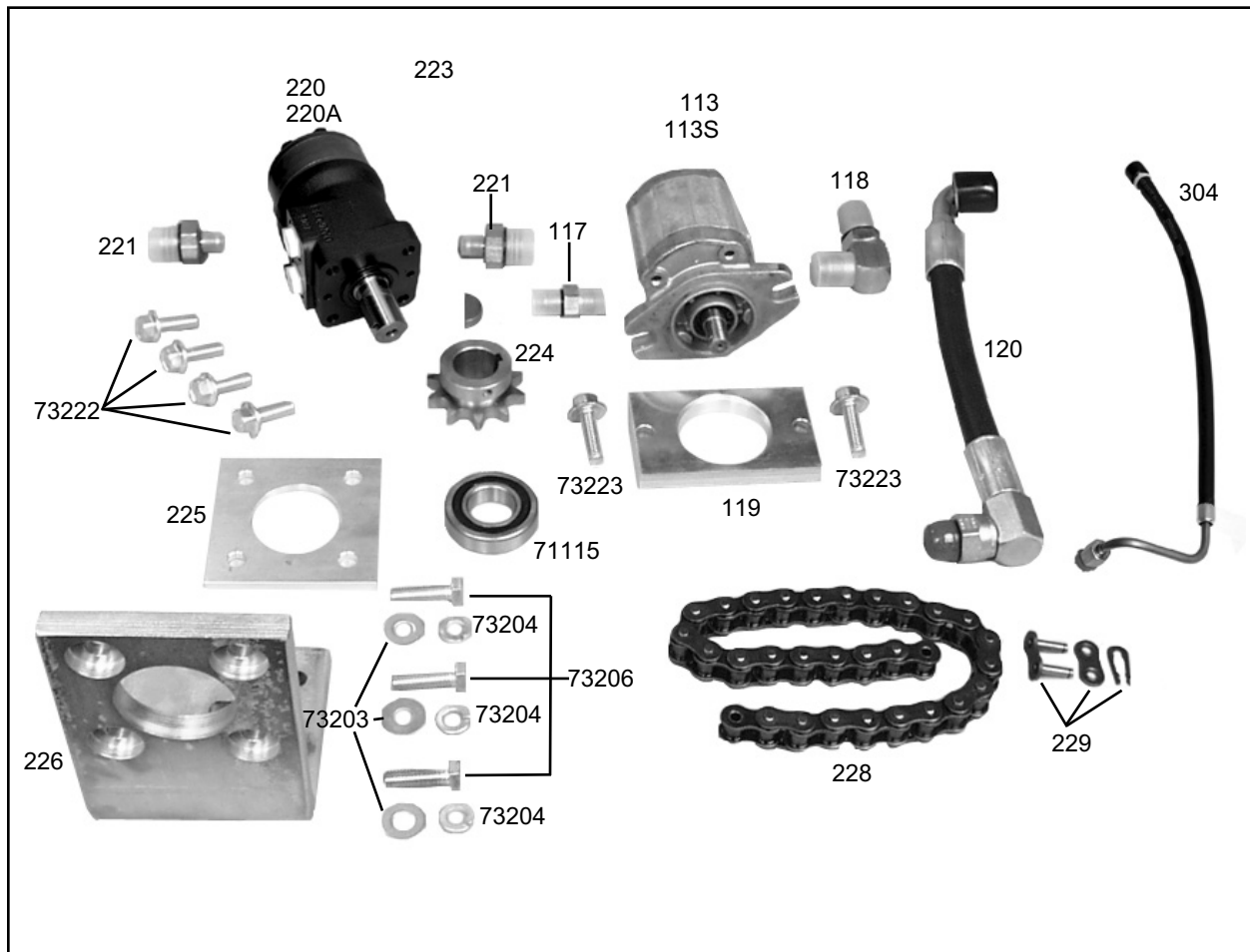

<u>PART #</u>	<u>DESCRIPTION</u>	<u>PART #</u>	<u>DESCRIPTION</u>
6280-113	Pump Non Spline (Old Style)	6280-225	Hydraulic Motor Spacer
6280-113A	Hydraulic Pump Key (Old Style) (Not Shown)	6280-226	Hydraulic Motor Mounting Bracket
6280-113S	Pump Splined (New Style)	6280-228	Drive Chain
6280-113-1	Seal Kit (Not Shown)	6280-229	Drive Chain Master Link Assembly
6280-117	Pressure Hose to Pump Connector	6280-304	Drain Hose
6280-118	Suction Hose to Pump Connector	71115	1 x 2 x 1/2 Bearing
6280-119	Pump Spacer	73203	3/8 Flat Washer (3)
6280-120	Suction Hose	73204	3/8 Split Washer (3)
6280-220	Hydraulic Motor (Old Style)	73206	3/8-16 x 1-1/4 Hexhead Bolt (3)
6280-220A	Hydraulic Motor (New Style)	73222	3/8-16 x 1 Wizlock Bolt (4)
6280-221	Hydraulic Motor Connector (2)	73223	3/8-16 x 1-1/4 Wizlock Bolt (2)
6280-223	Hydraulic Motor Shaft Key		
6280-224	Hydraulic Motor Sprocket		

# 6280 LABELS

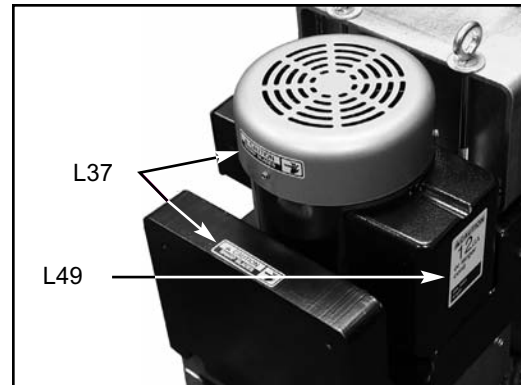
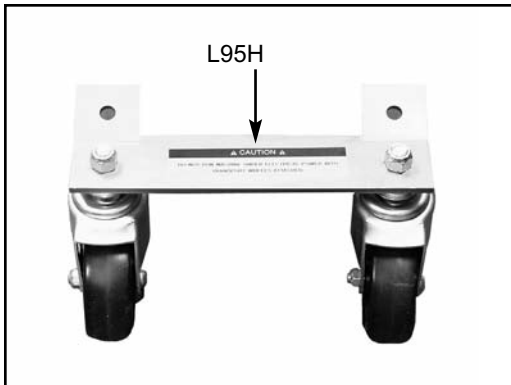
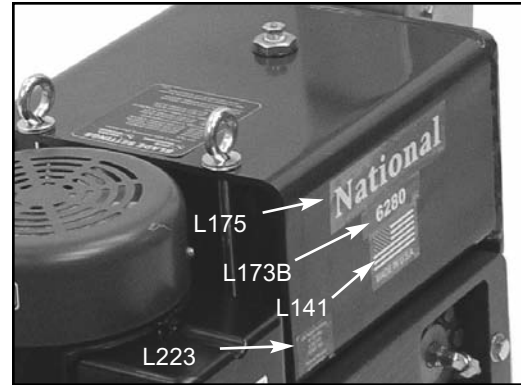
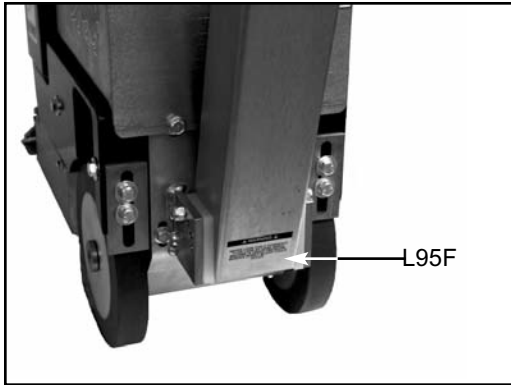

<u>PART #</u>	<u>DESCRIPTION</u>
L37	Caution Sharp Blade Label (2)
L49	Power Cord Label
L95F	Warning Fluid Leak Label
L95H	Caution Do Not Run Label
L95J	110 Volt Label (Not Shown)

<u>PART #</u>	<u>DESCRIPTION</u>
L141	Made In USA Label
L173B	Stock Number Label (2)
L175	National Label, Small (2)
L223	Patent Number Label

# 6280 LABELS

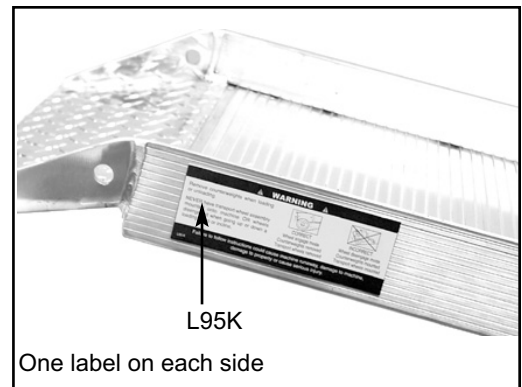
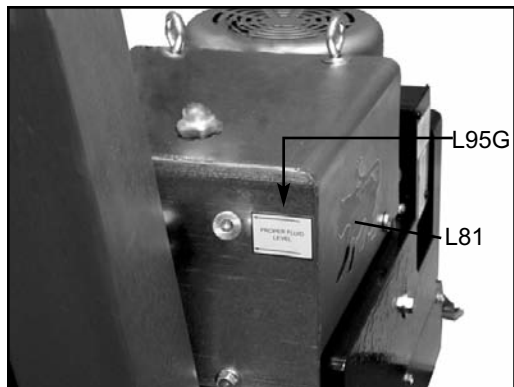
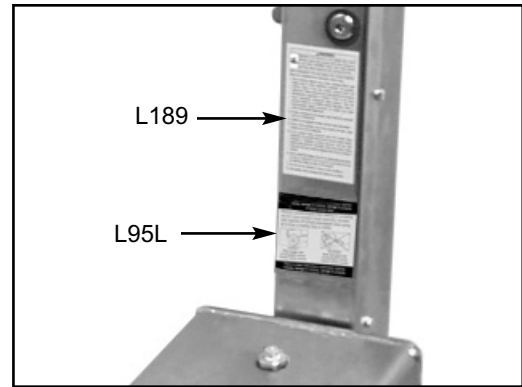
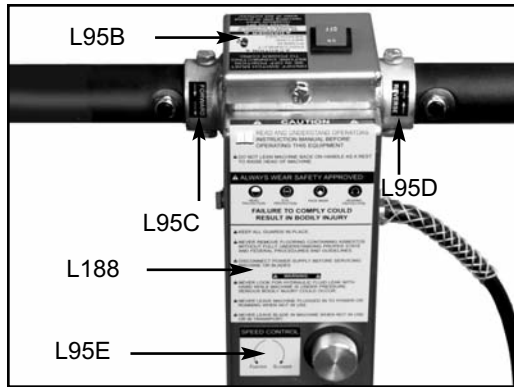

<b><u>PART #</u></b>	<b><u>DESCRIPTION</u></b>
L95B	On/Off Switch Label
L95C	Forward Label
L95D	Reverse Label
L95E	Speed Control Label
L95G	Fluid Level Label

<b><u>PART #</u></b>	<b><u>DESCRIPTION</u></b>
L95K	Ramp Label (2)
L95L	Remove Counterweights Label
L188	Caution General Info Label
L189	Safe Operating Tips Label

# 6280 ACCESSORIES

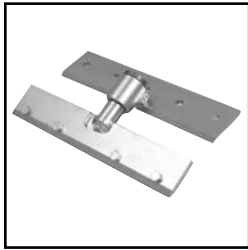

## #6280-500 SWIVEL HEAD ATTACHMENT

Unique Swivel Head rotates to use the second sharp edge of the blade without having to remove the blade. Designed to hold razor/scrapper blades. Works on thin soft coatings, paint and hard to remove gummy or dry adhesives. This attachment is the ultimate for adhesive removal. Swivel Head allows blade to stay in contact with the floor.

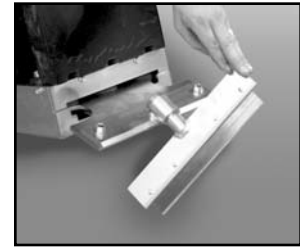

## #6280-502 OPTIONAL SADDLE WEIGHT

Adds an extra 50 lbs. to the drive wheels.



## #6251 LOADING RAMP

Durable light weight construction. Folds for easy transportation and storage.

#6251-1 Replacement Pinch Point Guard (set)

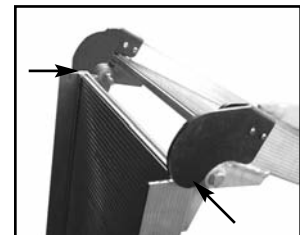

73220 or 73219

## #6280-146A ADDITIONAL FRONT WEIGHT

Mounts onto existing front weight. Adds 20 lbs. extra weight onto the cutting head.

73220 3/8-16 x 3 Hexhead Bolt (For 1 Additional Weight)

73219 3/8-16 x 5 Hexhead Bolt (For 2 Additional Weights)



## #6280-299 Front Transport Wheel Assembly

Makes movement of machine easier when transporting and helps to eliminate damage to flooring.

6280-300 Transport Wheel Bracket

6280-301 Replacement Wheel Only

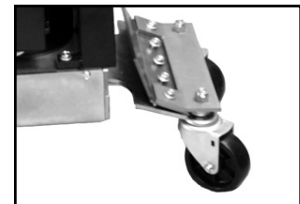

## #6254 50' POWER CORD

12 Gauge Power Cord

6254-1 Female Connector Only, 4729C

6254-2 Male Plug Only, 5266C

# 120 VOLT WIRING DIAGRAM

120 VOLT, 60 HZ

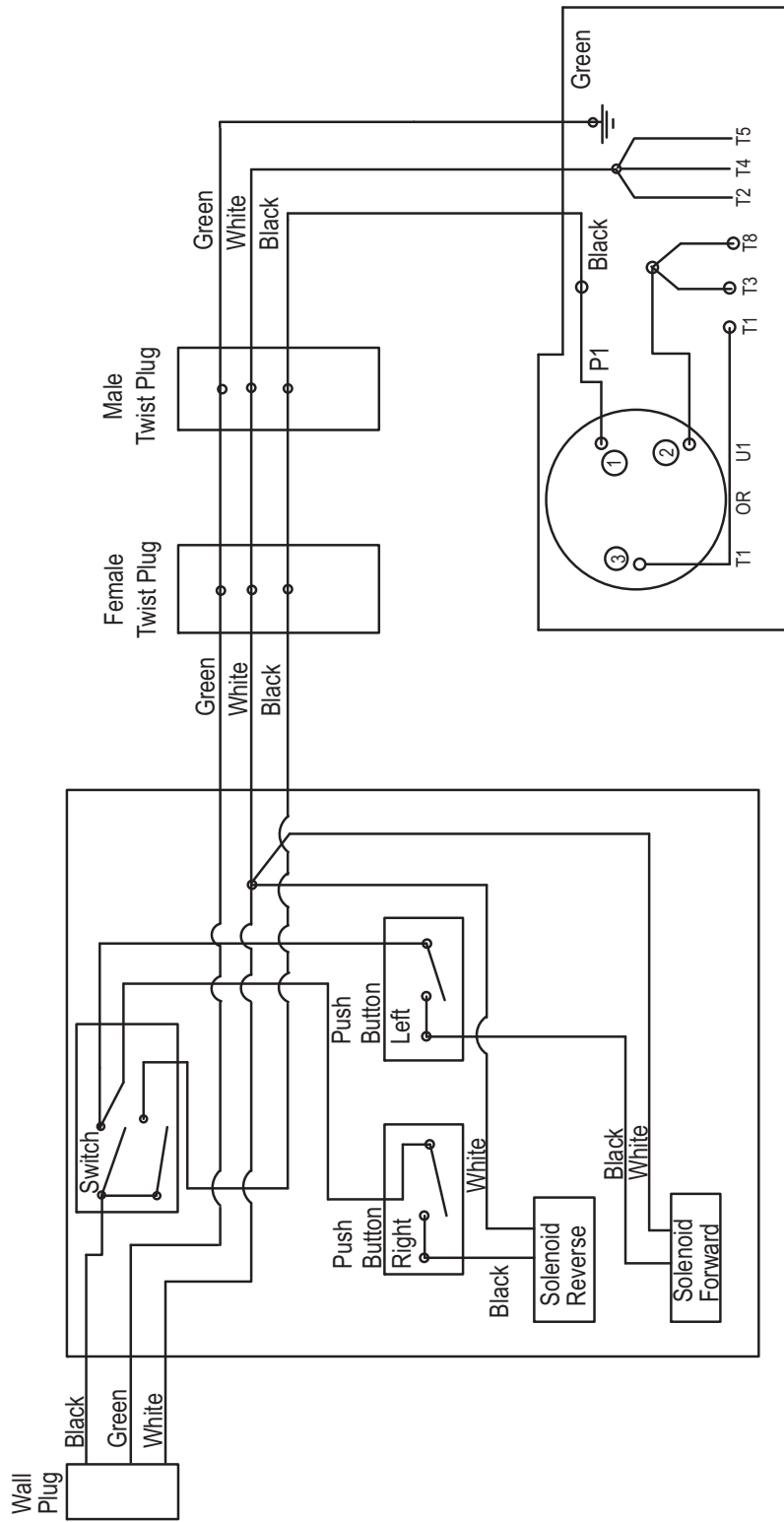

# 6280 HYDRAULIC LINE LAYOUT

## 6280 HYDRAULIC LINE LAYOUT

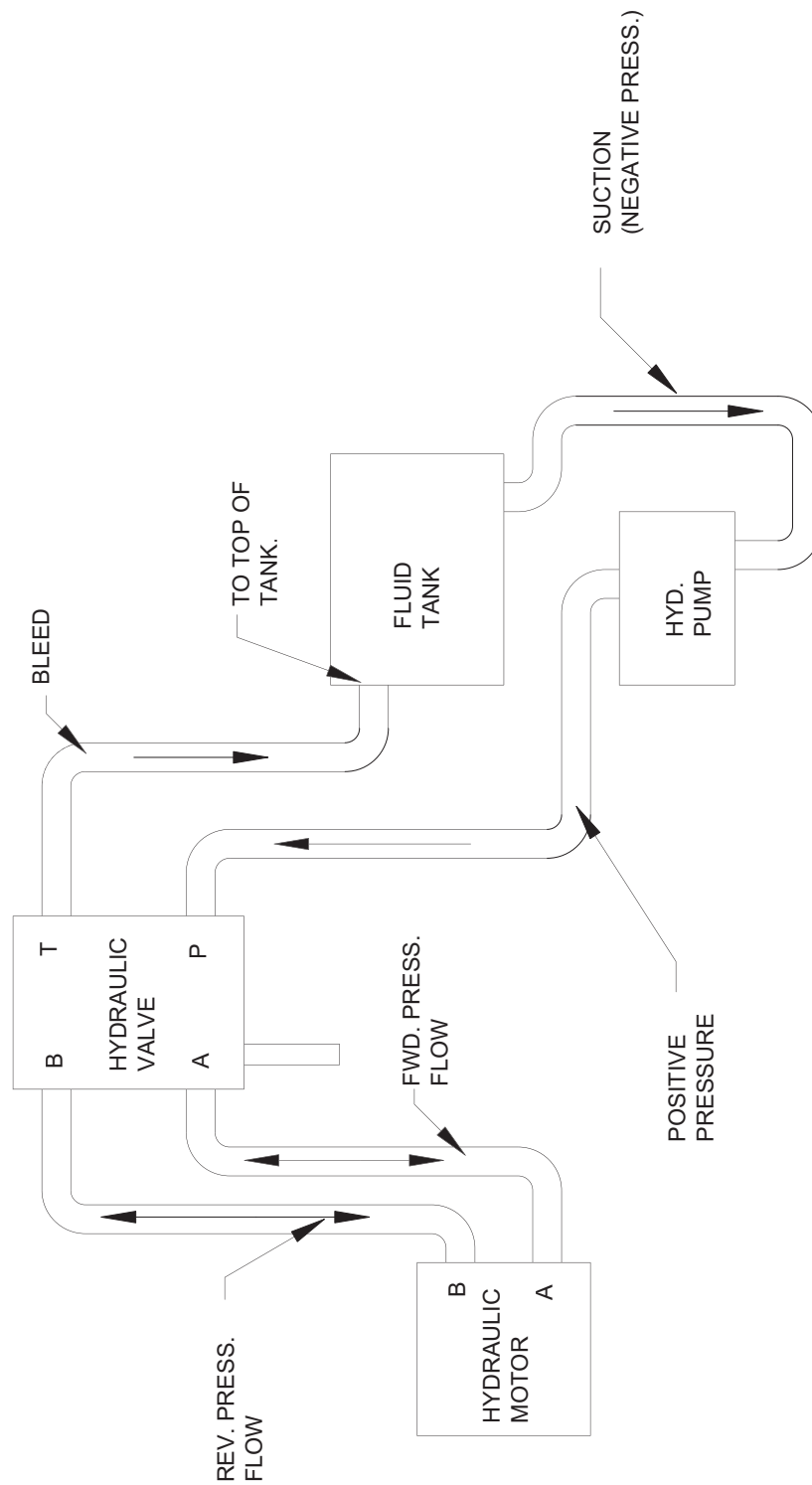



# 6280 MATERIAL SAFETY DATA

## Material Safety Data Sheet

### SECTION 1 PRODUCT AND COMPANY IDENTIFICATION

#### Texaco Rando® HD 22 - 68

**Product Number(s):** CPS221655, CPS221657, CPS221658, CPS221659

**Synonyms:** Texaco Rando® HD 22, Texaco Rando® HD 32, Texaco Rando® HD 46, Texaco Rando® HD 68

#### Company Identification

Chevron Products Company  
a division of Chevron U.S.A. Inc.  
6001 Bollinger Canyon Road  
San Ramon, CA 94583  
United States of America  
www.chevronlubricants.com

#### Transportation Emergency Response

CHEMTREC: (800) 424-9300 or (703) 527-3887

#### Health Emergency

Chevron Emergency Information Center: Located in the USA. International collect calls accepted. (800) 231-0623 or (510) 231-0623

#### Product Information

email : lubemsds@chevron.com  
Product Information: 800-LUBE-TEK  
MSDS Requests: 800-414-6737

### SECTION 2 COMPOSITION/ INFORMATION ON INGREDIENTS

COMPONENTS	CAS NUMBER	AMOUNT
Highly refined mineral oil (C15 - C50)	Mixture	90 - 100 %weight

### SECTION 3 HAZARDS IDENTIFICATION

#### IMMEDIATE HEALTH EFFECTS

**Eye:** Not expected to cause prolonged or significant eye irritation.

**Skin:** Contact with the skin is not expected to cause prolonged or significant irritation. Not expected to be harmful to internal organs if absorbed through the skin. High-Pressure Equipment Information: Accidental high-velocity injection under the skin of materials of this type may result in serious injury. Seek medical attention at once should an accident like this occur. The initial wound at the injection site may not appear to be serious at first; but, if left untreated, could result in disfigurement or amputation of the affected part.

**Ingestion:** Not expected to be harmful if swallowed.

**Inhalation:** Not expected to be harmful if inhaled. Contains a petroleum-based mineral oil. May cause respiratory irritation or other pulmonary effects following prolonged or repeated inhalation of oil mist at airborne levels above the recommended mineral oil mist exposure limit. Symptoms of respiratory irritation may include coughing and difficulty breathing.

### SECTION 4 FIRST AID MEASURES

**Eye:** No specific first aid measures are required. As a precaution, remove contact lenses, if worn, and flush eyes with water.

# 6280 MATERIAL SAFETY DATA

**Skin:** No specific first aid measures are required. As a precaution, remove clothing and shoes if contaminated. To remove the material from skin, use soap and water. Discard contaminated clothing and shoes or thoroughly clean before reuse.

**Ingestion:** No specific first aid measures are required. Do not induce vomiting. As a precaution, get medical advice.

**Inhalation:** No specific first aid measures are required. If exposed to excessive levels of material in the air, move the exposed person to fresh air. Get medical attention if coughing or respiratory discomfort occurs.

**Note to Physicians:** In an accident involving high-pressure equipment, this product may be injected under the skin. Such an accident may result in a small, sometimes bloodless, puncture wound. However, because of its driving force, material injected into a fingertip can be deposited into the palm of the hand. Within 24 hours, there is usually a great deal of swelling, discoloration, and intense throbbing pain. Immediate treatment at a surgical emergency center is recommended.

## SECTION 5 FIRE FIGHTING MEASURES

Leaks/ruptures in high pressure system using materials of this type can create a fire hazard when in the vicinity of ignition sources (eg. open flame, pilot lights, sparks, or electric arcs).

### FIRE CLASSIFICATION:

OSHA Classification (29 CFR 1910.1200): Not classified by OSHA as flammable or combustible.

**NFPA RATINGS:** Health: 0 Flammability: 1 Reactivity: 0

### FLAMMABLE PROPERTIES:

**Flashpoint:** (Cleveland Open Cup) 150 °C (302 °F) (Min)

**Autoignition:** No Data Available

**Flammability (Explosive) Limits (% by volume in air):** Lower: Not Applicable Upper: Not Applicable

**EXTINGUISHING MEDIA:** Use water fog, foam, dry chemical or carbon dioxide (CO<sub>2</sub>) to extinguish flames.

### PROTECTION OF FIRE FIGHTERS:

**Fire Fighting Instructions:** This material will burn although it is not easily ignited. For fires involving this material, do not enter any enclosed or confined fire space without proper protective equipment, including self-contained breathing apparatus.

**Combustion Products:** Highly dependent on combustion conditions. A complex mixture of airborne solids, liquids, and gases including carbon monoxide, carbon dioxide, and unidentified organic compounds will be evolved when this material undergoes combustion.

## SECTION 6 ACCIDENTAL RELEASE MEASURES

**Protective Measures:** Eliminate all sources of ignition in vicinity of spilled material.

**Spill Management:** Stop the source of the release if you can do it without risk. Contain release to prevent further contamination of soil, surface water or groundwater. Clean up spill as soon as possible, observing precautions in Exposure Controls/Personal Protection. Use appropriate techniques such as applying non-combustible absorbent materials or pumping. Where feasible and appropriate, remove contaminated soil. Place contaminated materials in disposable containers and dispose of in a manner consistent with applicable regulations.

**Reporting:** Report spills to local authorities and/or the U.S. Coast Guard's National Response Center at (800) 424-8802 as appropriate or required.

## SECTION 7 HANDLING AND STORAGE

**Precautionary Measures:** DO NOT USE IN HIGH PRESSURE SYSTEMS in the vicinity of flames, sparks and hot surfaces. Use only in well ventilated areas. Keep container closed.

**General Handling Information:** Avoid contaminating soil or releasing this material into sewage and drainage systems and bodies of water.

**Static Hazard:** Electrostatic charge may accumulate and create a hazardous condition when handling this material. To minimize this hazard, bonding and grounding may be necessary but may not, by themselves, be sufficient. Review all operations which have the potential of generating and accumulating an electrostatic charge and/or a flammable atmosphere (including tank and container filling, splash filling, tank cleaning, sampling, gauging, switch loading, filtering, mixing, agitation, and vacuum truck operations) and use appropriate mitigating procedures. For more information, refer to OSHA Standard 29 CFR 1910.106, 'Flammable and Combustible

# 6280 MATERIAL SAFETY DATA

Liquids', National Fire Protection Association (NFPA 77, 'Recommended Practice on Static Electricity', and/or the American Petroleum Institute (API) Recommended Practice 2003, 'Protection Against Ignitions Arising Out of Static, Lightning, and Stray Currents'.

**Container Warnings:** Container is not designed to contain pressure. Do not use pressure to empty container or it may rupture with explosive force. Empty containers retain product residue (solid, liquid, and/or vapor) and can be dangerous. Do not pressurize, cut, weld, braze, solder, drill, grind, or expose such containers to heat, flame, sparks, static electricity, or other sources of ignition. They may explode and cause injury or death. Empty containers should be completely drained, properly closed, and promptly returned to a drum reconditioner or disposed of properly.

## SECTION 8 EXPOSURE CONTROLS/PERSONAL PROTECTION

### GENERAL CONSIDERATIONS:

Consider the potential hazards of this material (see Section 3), applicable exposure limits, job activities, and other substances in the work place when designing engineering controls and selecting personal protective equipment. If engineering controls or work practices are not adequate to prevent exposure to harmful levels of this material, the personal protective equipment listed below is recommended. The user should read and understand all instructions and limitations supplied with the equipment since protection is usually provided for a limited time or under certain circumstances.

### ENGINEERING CONTROLS:

Use in a well-ventilated area.

### PERSONAL PROTECTIVE EQUIPMENT

**Eye/Face Protection:** No special eye protection is normally required. Where splashing is possible, wear safety glasses with side shields as a good safety practice.

**Skin Protection:** No special protective clothing is normally required. Where splashing is possible, select protective clothing depending on operations conducted, physical requirements and other substances in the workplace. Suggested materials for protective gloves include: 4H (PE/EVAL), Nitrile Rubber, Silver Shield, Viton.

**Respiratory Protection:** No respiratory protection is normally required.

If user operations generate an oil mist, determine if airborne concentrations are below the occupational exposure limit for mineral oil mist. If not, wear an approved respirator that provides adequate protection from the measured concentrations of this material. For air-purifying respirators use a particulate cartridge.

Use a positive pressure air-supplying respirator in circumstances where air-purifying respirators may not provide adequate protection.

## SECTION 9 PHYSICAL AND CHEMICAL PROPERTIES

Attention: the data below are typical values and do not constitute a specification.

**Color:** Yellow

**Physical State:** Liquid

**Odor:** Petroleum odor

**pH:** Not Applicable

**Vapor Pressure:** <0.01 mmHg @ 37.8 °C (100 °F)

**Vapor Density (Air = 1):** >1

**Boiling Point:** >315.6°C (600°F)

**Solubility:** Soluble in hydrocarbons; insoluble in water

**Freezing Point:** Not Applicable

**Melting Point:** Not Applicable

**Specific Gravity:** 0.86 - 0.87 @ 15.6°C (60.1°F) / 15.6°C (60.1°F)

**Density:** 0.86 kg/l - 0.9 kg/l @ 15°C (59°F)

**Viscosity:** 22 cSt - 61.2 cSt @ 40°C (104°F) (Min)

## SECTION 10 STABILITY AND REACTIVITY

**Chemical Stability:** This material is considered stable under normal ambient and anticipated storage and handling conditions of temperature and pressure.

**Incompatibility With Other Materials:** May react with strong acids or strong oxidizing agents, such as chlorates, nitrates, peroxides, etc.

**Hazardous Decomposition Products:** None known (None expected)

# 6280 MATERIAL SAFETY DATA

**Hazardous Polymerization:** Hazardous polymerization will not occur.

## SECTION 11 TOXICOLOGICAL INFORMATION

### IMMEDIATE HEALTH EFFECTS

**Eye Irritation:** The eye irritation hazard is based on evaluation of data for similar materials or product components.

**Skin Irritation:** The skin irritation hazard is based on evaluation of data for similar materials or product components.

**Skin Sensitization:** No product toxicology data available.

**Acute Dermal Toxicity:** The acute dermal toxicity hazard is based on evaluation of data for similar materials or product components.

**Acute Oral Toxicity:** The acute oral toxicity hazard is based on evaluation of data for similar materials or product components.

**Acute Inhalation Toxicity:** The acute inhalation toxicity hazard is based on evaluation of data for similar materials or product components.

### ADDITIONAL TOXICOLOGY INFORMATION:

This product contains petroleum base oils which may be refined by various processes including severe solvent extraction, severe hydrocracking, or severe hydrotreating. None of the oils requires a cancer warning under the OSHA Hazard Communication Standard (29 CFR 1910.1200). These oils have not been listed in the National Toxicology Program (NTP) Annual Report nor have they been classified by the International Agency for Research on Cancer (IARC) as; carcinogenic to humans (Group 1), probably carcinogenic to humans (Group 2A), or possibly carcinogenic to humans (Group 2B). These oils have not been classified by the American Conference of Governmental Industrial Hygienists (ACGIH) as: confirmed human carcinogen (A1), suspected human carcinogen (A2), or confirmed animal carcinogen with unknown relevance to humans (A3).

## SECTION 12 ECOLOGICAL INFORMATION

### ECOTOXICITY

This material is not expected to be harmful to aquatic organisms. The ecotoxicity hazard is based on an evaluation of data for the components or a similar material.

### ENVIRONMENTAL FATE

This material is not expected to be readily biodegradable.

## SECTION 13 DISPOSAL CONSIDERATIONS

Use material for its intended purpose or recycle if possible. Oil collection services are available for used oil recycling or disposal. Place contaminated materials in containers and dispose of in a manner consistent with applicable regulations. Contact your sales representative or local environmental or health authorities for approved disposal or recycling methods.

## SECTION 14 TRANSPORT INFORMATION

The description shown may not apply to all shipping situations. Consult 49CFR, or appropriate Dangerous Goods Regulations, for additional description requirements (e.g., technical name) and mode-specific or quantity-specific shipping requirements.

**DOT Shipping Description:** PETROLEUM LUBRICATING OIL, NOT REGULATED AS A HAZARDOUS MATERIAL FOR TRANSPORTATION UNDER 49 CFR

**Additional Information:** NOT HAZARDOUS BY U.S. DOT. ADR/RID HAZARD CLASS NOT APPLICABLE.

**IMO/IMDG Shipping Description:** PETROLEUM LUBRICATING OIL; NOT REGULATED AS DANGEROUS GOODS FOR TRANSPORT UNDER THE IMDG CODE

**ICAO/IATA Shipping Description:** PETROLEUM LUBRICATING OIL; NOT REGULATED AS DANGEROUS GOODS FOR TRANSPORT UNDER ICAO

# 6280 MATERIAL SAFETY DATA

## SECTION 15 REGULATORY INFORMATION

- EPCRA 311/312 CATEGORIES:** 1. Immediate (Acute) Health Effects: NO  
2. Delayed (Chronic) Health Effects: NO  
3. Fire Hazard: NO  
4. Sudden Release of Pressure Hazard: NO  
5. Reactivity Hazard: NO

**REGULATORY LISTS SEARCHED:**

01-1=IARC Group 1	03=EPCRA 313
01-2A=IARC Group 2A	04=CA Proposition 65
01-2B=IARC Group 2B	05=MA RTK
02=NTP Carcinogen0	6=NJ RTK
	07=PA RTK

No components of this material were found on the regulatory lists above.

**CHEMICAL INVENTORIES:**

All components comply with the following chemical inventory requirements: AICS (Australia), DSL (Canada), ENCS (Japan), IECSC (China), KECI (Korea), PICCS (Philippines), TSCA (United States).

One or more components is listed on ELINCS (European Union). Secondary notification by the importer may be required.

**NEW JERSEY RTK CLASSIFICATION:**

Under the New Jersey Right-to-Know Act L. 1983 Chapter 315 N.J.S.A. 34:5A-1 et. seq., the product is to be identified as follows: PETROLEUM OIL (Hydraulic oil)

**WHMIS CLASSIFICATION:**

This product is not considered a controlled product according to the criteria of the Canadian Controlled Products Regulations.

## SECTION 16 OTHER INFORMATION

**NFPA RATINGS:** Health: 0 Flammability: 1 Reactivity: 0

**HMIS RATINGS:** Health: 1 Flammability: 1 Reactivity: 0  
(0-Least, 1-Slight, 2-Moderate, 3-High, 4-Extreme, PPE:- Personal Protection Equipment Index recommendation, \*- Chronic Effect Indicator). These values are obtained using the guidelines or published evaluations prepared by the National Fire Protection Association (NFPA) or the National Paint and Coating Association (for HMIS ratings).

**LABEL RECOMMENDATION:**

Label Category : INDUSTRIAL OIL 1 - IND1

**REVISION STATEMENT:** This revision updates the following sections of this Material Safety Data Sheet: 2.  
**Revision Date:** January 15, 2007

**ABBREVIATIONS THAT MAY HAVE BEEN USED IN THIS DOCUMENT:**

TLV - Threshold Limit Value	TWA - Time Weighted Average
STEL - Short-term Exposure Limit	PEL - Permissible Exposure Limit
	CAS - Chemical Abstract Service Number
ACGIH - American Conference of Government Industrial Hygienists	IMO/IMDG - International Maritime Dangerous Goods Code
API - American Petroleum Institute	MSDS - Material Safety Data Sheet

# 6280 MATERIAL SAFETY DATA

CVX - Chevron	NFPA - National Fire Protection Association (USA)
DOT - Department of Transportation (USA)	NTP - National Toxicology Program (USA)
IARC - International Agency for Research on Cancer	OSHA - Occupational Safety and Health Administration

Prepared according to the OSHA Hazard Communication Standard (29 CFR 1910.1200) and the ANSI MSDS Standard (Z400.1) by the Chevron Energy Technology Company, 100 Chevron Way, Richmond, California 94802.

**The above information is based on the data of which we are aware and is believed to be correct as of the date hereof. Since this information may be applied under conditions beyond our control and with which we may be unfamiliar and since data made available subsequent to the date hereof may suggest modifications of the information, we do not assume any responsibility for the results of its use. This information is furnished upon condition that the person receiving it shall make his own determination of the suitability of the material for his particular purpose.**

# 6280 GUARANTEE

National Carpet Equipment, Inc. (National) warrants to the first consumer/purchaser that this National brand product (the #6280 Panther® Self-Propelled Stripper), when shipped in its original container, will be free from defective workmanship and materials and agrees that it will, at its option, either repair the defect or replace the defective product or part thereof at no charge to the purchaser for parts or labor for the period(s) set forth below.

This warranty does not apply to any appearance items of the product, to the additional excluded items set forth below, or to any product, the exterior of which has been damaged or defaced, which has been subjected to misuse, abnormal service or handling, or which has been altered or modified in design or construction.

In order to enforce the rights under this limited warranty, the purchaser should follow the steps set forth below and provide proof of purchase to National.

The limited warranty described herein is in addition to whatever implied warranties may be granted to purchasers by law. ALL IMPLIED WARRANTIES INCLUDING THE WARRANTIES OF MERCHANTABILITY AND FITNESS FOR USE ARE LIMITED TO THE PERIODS FROM THE DATE OF PURCHASE AS SET FORTH BELOW. Some states do not allow time limitations on an implied warranty, so the above limitation may not apply to you.

Neither the sales person of the seller, nor any other person, is authorized to make any other warranties other than those described herein, or to extend the duration of any warranties beyond the time period described herein on behalf of National.

The warranties described herein shall be the sole and exclusive warranties granted by National and shall be the sole and exclusive remedy available to the purchaser. Correction of defects in the manner and for the period of time described herein, shall constitute complete fulfillment of all liabilities and responsibilities of National to the purchaser with respect to the product and shall constitute full satisfaction of all claims, whether based on contract, negligence, strict liability or otherwise. In no event shall National be liable, or in any way responsible for any damage or defects in the product which were caused by repairs or attempted repairs performed by anyone other than National. Nor shall National be liable, or in any way responsible, for any incidental or consequential, economics or property damage. Some states do not allow the exclusion of incidental or consequential damages, so the above exclusion may not apply to you.

THIS WARRANTY GIVES YOU SPECIFIC LEGAL RIGHTS. YOU MAY ALSO HAVE OTHER RIGHTS WHICH VARY FROM STATE TO STATE.

## **WARRANTY PERIOD**

The #6280 Panther® Self-Propelled Stripper is guaranteed to be free of manufacturer defective workmanship and in quality of materials for a period of one year.

Items excluded from warranty coverage, unless found and reported defective immediately upon removal from the original shipping container and before being used by the original purchaser.

A freight damage claim must be filed with the carrier by the purchaser, the shipper cannot file the freight claim.

To obtain service contact National Carpet Equipment, Inc. toll free at 800-245-0267 for a repair authorization number. COD freight returns will not be accepted. Freight collect shipments will not be accepted. Warranty repairs must be accompanied by date of purchase receipt and a return/repair authorization number.

# 6280 RETURN SHEET

Company Name \_\_\_\_\_

Contact Name \_\_\_\_\_

Telephone Number \_\_\_\_\_

Approximate Usage (hours) \_\_\_\_\_

Problems Encountered \_\_\_\_\_

\_\_\_\_\_

\_\_\_\_\_

\_\_\_\_\_

\_\_\_\_\_

Check One:  Repair

Do you wish to be contacted before repairing  Yes  No

Return

Contact National if a loaner is needed

Return Authorization Number \_\_\_\_\_ Date \_\_\_\_\_  
required, contact National

Customer Number \_\_\_\_\_  
if known

Purchased From \_\_\_\_\_  
if not directly from National

## INTERNAL USE ONLY

Date Received \_\_\_\_\_

Unit Serial Number \_\_\_\_\_

Subject To Warranty \_\_\_\_\_



# 6280 BLADE ORDER FORM

Part #	Description	Thickness	Quantity
#130-S	3" x 10" Blade with Slots	.062	
#130-D	3" x 10" Double Edge Blade	.062	
#131-S	3" x 16" Blade with Slots	.062	
#135	5" x 16" Blade	.062	
#136	5" x 8" Blade	.062	
#147	4" x 6" Blade	.062	
#147-D	4" x 6" Double Edge Blade	.062	
#148	5" x 6" Blade	.062	
#148-D	5" x 6" Double Edge Blade	.062	
#363-2	3/4" x 8" Scraper Blade (50/pkg)	.032	
#368-8	7/8" x 8" Razor/Scraper Blade (50/pkg)	.045	
#368-12	7/8" x 12" Razor/Scraper Blade (50/pkg)	.045	
#368-15	7/8" x 15" Razor/Scraper Blade (50/pkg)	.045	
#6253	Panther Ripper Teeth	.062	
#6255-BU	4" x 6" Self Scoring Blade	.062	
#6257-BU	3" x 9" Self Scoring Blade	.062	
#6258-BU	3" x 12" Self Scoring Blade	.062	
#6259-BU	3" x 14" Self Scoring Blade	.062	
#6277-BU	3" x 12" Self Scoring Blade	.094	
#6278-BU	3" x 14" Self Scoring Blade	.094	
#6270	1-1/2" x 3" Extra Heavy Duty Blade	.250	
#6271	3" x 6" Extra Heavy Duty Blade	.250	
#6273	3" x 11" Extra Heavy Duty Blade	.250	
#6280-500	Swivel Head Attachment		
#6281	3" x 8" Heavy Duty Blade	.094	
#6282	3" x 14" Heavy Duty Blade	.094	
#6284	3" x 12" Heavy Duty Blade	.094	
#6285	3" x 6" Heavy Duty Blade	.094	
#6286	3" x 10" Heavy Duty Blade	.094	
#6290	3" x 6" Extra Heavy Duty Blade	.187	
#6291	3" x 8" Extra Heavy Duty Blade	.187	
#6292	3" x 12" Extra Heavy Duty Blade	.187	
#6293	3" x 14" Extra Heavy Duty Blade	.187	
#7050-200	3" x 6" Premium High Temp Blade	.062	
#7050-201	3" x 8" Premium High Temp Blade	.062	
#7050-202	3" x 10" Premium High Temp Blade	.062	
#7050-203	3" x 12" Premium High Temp Blade	.062	
#7050-204	3" x 14" Premium High Temp Blade	.062	
#7080	3" x 8" Increased Angle Blade	.062	
#7081	3" x 10" Increased Angle Blade	.062	

**BILL TO:**

Attn: \_\_\_\_\_

Company: \_\_\_\_\_

Address: \_\_\_\_\_

Phone: \_\_\_\_\_

**SHIP TO:**

Attn: \_\_\_\_\_

Company: \_\_\_\_\_

Address: \_\_\_\_\_

Phone: \_\_\_\_\_

**TO ORDER:**

Phone: 800-245-0267 or 763-535-8206

Fax: 800-648-7124 or 763-535-8255

Online: [www.nationalequipment.com](http://www.nationalequipment.com)

All orders and payment terms to be verified prior to shipping.

National Carpet Equipment, Inc. • 9250 Xylon Avenue N. • Minneapolis, MN 55445

Phone 800-245-0267 or 763-535-8206 • Fax 800-648-7124 or 763-535-8255

Web Site: [www.nationalequipment.com](http://www.nationalequipment.com) • E-Mail: [info@nationalequipment.com](mailto:info@nationalequipment.com)